



**IMPROVING THE EFFICIENCY OF SUGARCANE  
PRODUCTION USING INTERNET OF THINGS (IOT):  
THE CASE OF WONJI/SHOA SUGAR FACTORY**

**A Thesis Presented**

**by**

**Biruk Abate Demisse**

**to**

**The Faculty of Informatics**

**of**

**St. Mary's University**

**In Partial Fulfillment of the Requirements  
for the Degree of Master of Science**

**in**

**Computer Science**

**April, 2021**

# ACCEPTANCE

**Improving the Efficiency of Sugarcane Production using Internet of Things  
(IoT): The Case of Wonji/Shoa Sugar Factory**

**By**

**Biruk Abate Demisse**

**Accepted by the Faculty of Informatics, St. Mary's University, in partial  
fulfillment of the requirements for the degree of Master of Science in  
Computer Science**

**Thesis Examination Committee:**

**Internal Examiner**

**Michael Melese (Ph.D.)**

**Full Name**

\_\_\_\_\_

**Signature**

\_\_\_\_\_

**Date**

**External Examiner**

**Muluneh Mekonnen (Ph.D.)**

**Full Name**

\_\_\_\_\_

**Signature**

\_\_\_\_\_

**Date**

**Dean, Faculty of Informatics**

**Getahun Semeon (Ph.D.)**

**Full Name**

\_\_\_\_\_

**Signature**

\_\_\_\_\_

**Date**

**April, 2021**

## DECLARATION

I, the undersigned, declare that this thesis work is my original work, has not been presented for a degree in this or any other universities, and all sources of materials used for the thesis work have been duly acknowledged.

Biruk Abate Demisse

---

---

Signature

Addis Ababa

Ethiopia

This thesis has been submitted for examination with my approval as advisor.

Asrat Mulatu (Ph.D.)

---

---

Signature

Addis Ababa

Ethiopia

April, 2021

## **ACKNOWLEDGEMENTS**

I would like to express my gratitude to all those who enriched this study both directly and indirectly. Special mention goes to:

Asrat Mulatu (Ph.D.), my Advisor, for the guidance you gave in the writing of this Thesis. You cleared many of obstacles for me along the way and I thank you,

To Habtamu Demissie, and G.G; your tremendous support, especially in conceptualizing and putting the ideas in this research together was invaluable; you directed and gave shape to this study, thank you very much;

I would like to thank Sugarcane Research Center and Plantation office Agriculture Experts at Wonji/Shoa Sugar factory for granting me the permission to undertake the research work and use the Organization as my case study and

My deepest gratitude goes to my mather Zewide Negasa Wordofa, my sister and brothers, who have been the driving inspiration to my completion of this study program.

Biruk A. Demisse

April, 2021

# TABLE OF CONTENTS

ACKNOWLEDGEMENTS .....	i
TABLE OF CONTENTS .....	ii
LIST OF ACRONYMS AND ABBREVIATIONS .....	iv
LIST OF FIGURES .....	v
LIST OF TABLES .....	vi
ABSTRACT .....	vii
1.1 Background .....	1
1.2 Statement of the Problem .....	4
1.3 Research Questions .....	5
1.4 Objectives.....	5
1.4.1 General objective.....	5
1.4.2 Specific Objective .....	6
1.6 Contributions of the research.....	6
1.7 Scope of the Study.....	7
1.8 Limitations of the Study .....	7
1.9 Organization of the Thesis.....	7
2.1 Overview .....	9
2.2 Internet of Things .....	9
2.2.1 Applications of IOT.....	11
2.2.1.1 Application Area of IoT in Agriculture.....	15
2.2.2 Internet of Things Architecture .....	19
2.2.3 Communication framework Structure of IoT .....	20
2.3 Sugarcane Production in Ethiopia .....	21
2.3.1 Standard Operating Procedures for Sugarcane Production at Wonj/Shoa Sugar Estate.....	22
2.3.2 Factors affecting Productivity of sugarcane Production.....	23
2.4 Related Works .....	23
3.1 Overview .....	30
3.2 Description of the Study Area .....	30
3.3 Research Design .....	31

3.4 Research Methodology .....	32
3.4.1 Target Population .....	32
3.4.2 Sampling Design .....	32
3.4.3 Methods of Data Collection and Tools.....	33
3.4.4 Method of Data Analysis.....	33
3.4.5 System Evaluation .....	34
4.1 Overview .....	35
4.2 Requirement Analysis.....	35
4.2.1 Factors Affecting Sugarcane Production.....	35
4.2.2 Challenges faced in sugarcane Production .....	37
4.2.3 Comparison with other existing solution.....	38
4.3 Proposed System Architecture.....	40
4.3.1 System Architecture .....	40
4.4 Requirement Specification .....	42
4.4.1 Software Requirement .....	42
4.4.2 Hardware Requirement.....	43
4.4.3 Platform Requirement .....	47
4.5 System Design.....	48
4.5.1 Design Goal.....	48
4.5.2 Sub -System Decomposition .....	49
5.1 Overview .....	53
5.2 Implementation.....	53
5.2.1 Development tools.....	53
5.2.2 Prototype .....	57
5.2.3 Testing .....	62
5.2.4 Result and Discussion.....	65
6.1 Conclusions .....	67
6.2 Future Works.....	68
REFERENCES .....	69
APPENDIX .....	73

## LIST OF ACRONYMS AND ABBREVIATIONS

<b>API</b>	Application Programing Interface
<b>ESISC</b>	Ethiopian Sugar Industry Support Center Share Company
<b>CSA</b>	Central Statistical Agency
<b>GDP</b>	Gross Domestic Product
<b>GPRS</b>	General Packet Radio Service
<b>GSM</b>	Global Subscribe Module
<b>IDE</b>	Integrated Development Environment
<b>IMS</b>	Intelligent Maintenance Systems
<b>IoT</b>	Internet of Things
<b>M2M</b>	Machine to Machine
<b>NTC</b>	Negative Temperature Coefficient
<b>OTP</b>	One Time Programmable
<b>RFID</b>	Radio Frequency Identification
<b>SOP</b>	Standard Operational Procedures
<b>SSADM</b>	Structured Systems Analysis and Design Method
<b>UART</b>	Universal Asynchronous Receiver-Transmitter
<b>URN</b>	Uniform Resource Network
<b>WiFi</b>	Wireless Fidelity
<b>WLAN</b>	Wireless Local Area Network
<b>WSN</b>	Wireless Sensor Networks
<b>WSSF</b>	Wonji Shoa Sugar Factory
<b>XML</b>	Xtensive Markup Language

## LIST OF FIGURES

Figure 2.1: Description of IoT [9].....	10
Figure 2.2: Application of IoT [9] .....	19
Figure 3.1: Wonji/Shoa Sugar Factory Sugarcane Plantation Area.....	31
Figure 4.1: Proposed System Architecture for sugarcane plant monitoring.....	40
Figure 4.2: Different types of Sensors uses in gather information from field .....	41
Figure 4.3: The Arduino Mega 2560 .....	43
Figure 4.4: Soil moisture sensor .....	45
Figure 4.5: DHT11 sensor.....	46
Figure 4.6: A6 GSM/GPRS module .....	47
Figure 4.7: Sub- system Architecture .....	50
Figure 4.8: Sequence Diagram for the proposed system .....	50
Figure 4.9: Process flow .....	51
Figure 5.1: Moisture sensor with Arduino Connection .....	54
Figure 5.2: DHT11 sensor with Arduino Connection.....	55
Figure 5.3: Include DHT Library .....	56
Figure 5.4: A6 GSM Module Arduino Connection .....	57
Figure 5.5: Implementing of the prototype Sugarcane Plant .....	57
Figure 5.6: Creating New Channels.....	58
Figure 5.7: Created Channels on the ThingSpeak .....	59
Figure 5.8: Generating New API Key.....	59
Figure 5.9: Read and Output of Soil moisture .....	60
Figure 5.10: Read and Output of Temperature and Humidity .....	60
Figure 5.11: Output of soil moisture ThingSpeak Result .....	61
Figure 5. 12: Output of Humidity and Temperature ThingSpeak Result .....	61



## LIST OF TABLES

Table 2.1: Summary of related works.....	28
Table 3.1: Target Population.....	32
Table 5.1: Evaluation Question.....	62
Table 5.2: Evaluation Result.....	64

## ABSTRACT

Sugarcane is an important sugar crops in Ethiopia and has been planted hottest area in Ethiopia, it is the major income source of sugarcane growers but traditional manual operation still applied on sugarcane planting and management at present, leading to higher labor costs. There are many technologies to increase productivity of sugarcane, some of which include IoT Technology, mechanization farming and so on. Internet of Things (IoT) In the agricultural sense, Sugarcane development challenges refers to the use of sensors, cameras, and other technologies to turn any aspect and activity involved in farming into big data. In this analysis, an IoT-based system for growing sugarcane production was developed. They use embedded computers to collect real time critical information for sugarcane field production such as temperature, humidity and moisture sensors. In this research applied research design methodology is used to design and developed an IoT based prototype for improving sugarcane production.

In the study, different devices and technologies were interconnected to create an embedded system and collect real time data in the field. The systems inter-connected were GSM/GPRS module, Grove Sensors, DHT11 sensor, Arduino microcontroller and Thing Speak platform. The testing and evaluation results also confirm that study was more relevant in their sugarcane production sectors, and they future to use the prototype in different ways. With the use such tools are some improvements in sugarcane can be realized in capturing the cane filed data. In addition, the thesis provides contributions to knowledge base by identifying the factors affecting and challenge facing of the production of sugarcane at Wonji. As a result, to improve sugarcane productivity to developed and design an artifact, this could serve as a template for the implementation of such artifact elsewhere.

# CHAPTER ONE

## INTRODUCTION

### 1.1 Background

Agriculture is the backbone of the Ethiopian economy [1]. This particular sector determines the growth of all other sectors and consequently the national economy. It constitutes over 50% of the gross domestic product (GDP), accounts for over 85% of the labor force and earns over 90% of the foreign exchange. On average, crop production makes up 60% of the sector's outputs, whereas livestock accounts for 27% and other areas contribute 13% of the total agricultural value added. The sector is dominated by small-scale farmers who practice rain-fed mixed farming by employing traditional technology, adopting a low-input and low-output production system. The land tilled by the Ethiopian small-scale farmer accounts for 95% of the total area under agricultural use, and these farmers are responsible for more than 90% of the total agricultural output. Some of the agricultural products that Ethiopia produces are tef, maize, burly, sorghum, avocado, mango, banana, sugarcane etc.

Sugarcane is a crop has planted in hottest area in our country and the major income source of out growers' farmers around Wonji. Sugar development sector is one among other huge projects, which enables industry take a leading role in the nation's economy. Ethiopia has huge human as well as natural resources which enable the nation to broaden this export-oriented manufacturing industry sector and its productivity. The nation has suitable climate, 1.4 Million hectares wide and proved irrigable agricultural land as well as abundant resource of water and ample labor resource. The government has given higher attention to the sector and it is working for further development of it. The country is rich with resources like suitable climate, fertile land and abundant water supply, which are favorable for sugarcane development. Hence, it is possible to cultivate 162 tons of sugarcane per hectare on average in 15 months. In relation to the productivity, it is possible to produce 10.8 tons of sugarcane in Ethiopia per month and when compared against the global sugarcane production potential it outstrips the global production per hectare in 2.3 tons (Ethiopian Sugar Corporation) [2]. As Wonji/Shoa Estate Farm is the first producers of sugarcane in Ethiopia, it is also suffering

from the low production and productivity of sugar cane, thus in this paper a different attempt was made to examine the reason for low production and productivity of sugar cane in Wonji/Shoa Estate Farm by using the technical efficiency.

Internet of Things (IoT) is a method of connecting everything to the internet - it is connecting connected with each other [3]. Main purpose of IoT is ensuring delivery of right information to right people at right time [3]. IoT can be used for monitoring and tracking of different domains such as Health domain, Environmental domain, Utility domain, Logistics domain and Agricultural domain. Agriculture domain by connecting group of objects (things) associated with sensors and internet from remote places and to making automat the farm and achieving desired quality result. IoT is changing the agriculture activity and empowering farmers to fight against huge difficulties they face. The agriculture must overcome expanding water deficiencies problems, restricted availability of lands, while meeting the expanding consumption needs of a world population.

New innovative IoT applications are addressing these issues and increasing the quality, quantity, sustainability and cost effectiveness of sugarcane production [3]. Technology, particularly the IoT technologies is will play a fundamental role in improving sugarcane farming. The primary driver is the challenge of raising yields and different production costs but this has many additional benefits in terms of more efficient labor and material costs.

In Agricultural context IoT technology Addressed in Sugarcane Production Challenges to the use of sensors, cameras, and other devices to turn every element and action involved in farming into big data. Weather, moisture, plant health, mineral status, chemical applications, pest presence and much more can all to be turned into large data sets. IoT itself not a product or particular tool, but one of a family of technologies. The aim of most agriculture IoT products is to enable Agriculturalist to use these insights to make operational decisions around planting, irrigating, harvesting and more [4].

Now a day's recent areas of IoT applications in agriculture areas are:

1. Wireless Network system (Sensor-based) for monitoring crop growth, soil fertility, fields monitoring, livestock control, storage facilities, or any important factor that influences the production.
2. Analysis of data, visualization and management systems.

The Objectives of this research developed a prototype based up on IoT technology for improving the efficiency of sugarcane production. The uses embedded computers to collect real time critical information for sugarcane field production such as temperature, humidity and moisture sensors. The sensors transmit data from field to Wireless networks for Thingspeak platform and save it on Channels and display it graphically. Then finally the real-time data of the cane filed production conditions was collect to agronomist and analyzes the data and identify the problem and taking an action and improve the efficiency of production of sugarcane. In this research Arduino UNO microcontroller board, ThingSpeak platform and the different sensors to sense the data from the field are used to design and develop the prototype.

ThingSpeak is a network platform that enables things to communicate via an internet connection, and serves as a "data packet" carrier between the attached IoT objects and the ThingSpeak cloud platform to retrieve, save/store, evaluate, observe, and operate on the sensed data from the connected sensor to the host microcontroller board such as an "Arduino," a "TI CC3200 card," a "Raspberry Pi, etc. ThingSpeak is a web based open API IoT platform that comprehensive in storing the sensor data of varied 'IoT applications' and conspire the sensed data output in graphical form at the web level [5]. The Thingspeak 'Cloud' utilizing the operations of graphical visualization and available in the form of virtual server for the users and the things are communicated with the cloud via possible 'wireless internet connections' available to the users and majority of the things are uses the sensors to tell regarding our environmental analogue data. The IoT Helps to bring all things together and permits us to communicate with our very own things and even more curiously allows objects/things to interact with other 'things' [5].

This study, to uses microcontroller Arduino is an open-source platform comprising of both a Physical Programmable Circuit Board (often referred to as a microcontroller) and a piece of software that can be installed on the computer, used to write and upload computer code to the physical board [6]. The Arduino software works on all known operating systems. It is an Integrated Development Environment (IDE) that provides programmers with tools such as a source code editor, automation tools, and a debugger [7].

A recent study shows that temperature and humidity sensors are being used for measurements and are connected with the IoT network, in concluding that by using IoT, the whole process is automated and data are collected using sensors. Thus, there was a need to design a system for improving the productivity of sugarcane prototype using the IoT technology in order to manage and control sugarcane field productivity.

## **1.2 Statement of the Problem**

There is little effort to increase sugarcane production in our country with the help of technology. The main reason for the decline in sugarcane production is the lack of proper water supply to the plant. To solve this problem, it is possible to make an informed decision and technical solve the problem and improve the sugarcane production using IoT technology. Despite this, the current failure in sugarcane production is largely due to climate change. The climate changes the most significant challenges for sugarcane production are increases in frequency and intensity of extreme weather events, especially drought during climate change [ 11]. With this in mind, there is little that can be done directly on the basis of factual information to solve the problem: Temperature, humidity and moisture level of the soil. Sugarcane has been shown to cause significant water shortages associated with irrigation. Water productivity largely depend on the agroclimatic zone, soil condition, irrigation water management; including the amount of water, irrigation technology, irrigation schedule [8]. The main problem is the lack of knowledge of measuring the yield of sugarcane and providing the plant with the water it needs, and the fact that too much or too little water for sugarcane can cause problems for the production of sugarcane. Reduction of sugarcane production is a major problem in determining the irrigation interval and irrigation frequency, which is a major problem in the lack of technology. The current situation was not based on any data, but only on the observation of the soil and the problem of waterlogging. When we need to know what kind of weather, we need to irrigate sugarcane production only when we know how to use it. Therefore, by solving this problem, IoT technology can be used to improve the efficiency of sugarcane production and to solve the problems by using the information from different sensors. In this study, environmental conditions of sugarcane plant data are collected by using different sensor and the sensed data transmitted to the Internet by the wireless sensor network and a gateway unit handles the sensor information, and transmits data to web

applications. Using IoT wireless networks distributed, soil moisture, humidity and temperature sensors installed in the field's zone of the plants to monitor the environmental conditions and irrigation level. Soil moisture, humidity and temperature sensors uses to senses, measures and reports the relative humidity and temperature in the air and the soil moisture senses the level of wetness of the soil. In addition, through ThingSpeak platform collected data can be analyzed, stored and visualized using graphs and charts to give a better understanding of environmental conditions to the Agronomist. it helps for those who are engaged in cane protection and monitoring activities like filed coordinators and Agronomist in organizations for watering and environmental condition of the plant the right time in the right place.

The aim of this research is based up on the problems in Wonji sugar factories focuses on to irrigation of water in a right time in right place by using WNS data for right decision so, developing the prototype to fill the gap in improving the sugarcane Production by using IoT technology. Thus, technology supports by sensors like soil moisture sensor, temperature sensor, humidity sensor and those sensors to control by microcontroller and the sensors data to sends through the internet and the data put the cloud, finally analyze the recorded data to the uses making better decision for Agronomist and decision makers. This IoT Technology can address problems and improves sugarcane production answering following research question.

### **1.3 Research Questions**

To achieve the aim of the study, the current work investigates and answers the following research questions:

1. What types of IoT Technologies Improve Sugarcane Production?
2. How to determine the suitability of the soil moisture and weather conditions for Sugarcane using IoT?
3. How to improve the sugarcane Production by using IoT Technology?

### **1.4 Objectives**

#### ***1.4.1 General objective***

The General objective of the study is to Improving the Efficiency of Sugarcane Production

using IoT at Wonji/Shoa Sugarcane Estate Plot.

### ***1.4.2 Specific Objective***

The specific objectives are: -

- To Identify and understand factors affecting improving sugarcane production to improve IoT among the Wonji Sugarcane Estate firms.
- Challenges faced by technical efficiencies of improving the sugarcane production?
- Identify IoT technology to increase sugarcane production and demonstrate how to use to solve problems.
- Design IoT Prototype in Improving the Efficiency of Sugarcane Production.
- Test the Prototype.
- Comparatively evaluate the solution with respect to other similar solutions improving sugarcane production technological.

### **1.6 Contributions of the research**

The Contributions of the research in practical aspects in sugarcane production are: -

- Involves the observation, measurement, and control of sugarcane plants and equipment.
- Manages and Reducing wastages of water and uses efficiently done using IoT.
- Supports or helps to continuous monitor the land so that precautions can be taken at early stage.
- It increases productivity, reduce manual work, reduce time and makes farming more efficient.
- Contribution of in facilitating management in decision-making.
- Increasing Job satisfaction.
- Reduced resource wastage plenty of agricultural IoT solutions are focused on optimizing the use of resources like water, energy and land. Using IoT relies on the data collected from diverse sensors in the field, which helps agronomist accurately allocate just enough resources to within a field.



- Improved product quality data-driven agriculture helps both grow more and better products.

### **1.7 Scope of the Study**

This study aimed to assess the contribution of IoT technologies focused on to improve the sugar cane productivity such as Soil Moisture, Humidity and Temperature level to implement in Wonji/Shoa Sugar Factories. In addition, this research implements hardware equipment's like sensors, microcontroller, GSM modular, internets and its technology.

### **1.8 Limitations of the Study**

There is not much research on how to solve the problems to improve sugarcane production and how to grow it using technology and there is no one who has enough knowledge and expertise to support the technologies. Lack of literature in the improving sugarcane productivity using IoT Technologies and lack of recent study in the sugarcane productivity area in Ethiopia. since IoT Technology is relatively new in our country it also makes it difficult to find the resources that the technology requires. Lack of IoT Technology to increase sugarcane production is a barrier to understanding and resolving plant problems, particularly soil moisture, temperature and humidity.

In this study requires hardware IoT materials such as sensors, microcontrollers, and network communications tools (GSM / GPRS), which are considered to be obstacles to this study because those are costly and difficult to obtain and there is a lack of knowledge to understand the technology after the prototype implementation. Finally, the results of this IoT Technology can be seen as limitation of our country's Internet infrastructure problem by conducting various analysis for improving production of sugarcane of and making various emergency decisions.

### **1.9 Organization of the Thesis**

This thesis is an organize into different chapters: Chapter One deals with the background of the study, statement of the Problem, the researchable Question and methodology followed the Objective, Contributions, The Scope and Limitation of the study. In Chapter two section discussed the concept of IoT with different layered architectures, application area of IoT,

application area of IoT in Agriculture, Communication frame work of IoT, overview of Sugarcane Production standard operation procedures activities for sugarcane fields, factors affecting sugarcane production and finally discussed related work done in this area and summarize with observed challenges and gap identified the in the review. Chapter three covered areas of the study, research design, data collection methods, sampling procedures, method of data analysis, Evaluation Criteria and Ethical Concerns. The fourth chapter discussed the requirement analysis and design were discussed. The fifth chapter discussed in detail the implementation and design were discussed in detail. The final chapter six discussed conclusion and future work are discussed.

## **CHAPTER TWO**

### **REVIEW OF RELATED WORKS**

#### **2.1 Overview**

In this chapter various materials that had been reviewed to understand the state-of-the-art for Improving Sugarcane production using IoT. The review includes; research articles, journal, thesis, conference papers and standard operation manuals that are related to the research topic have been examined. Besides, we had reviewed related works to identify the research gap, formulate the problem statement and research questions of the study. In the following section discussed the concept of IoT with different layered architectures, application area of IoT, application area of IoT in Agriculture, Communication frame work of IoT, overview of Sugarcane Production in Ethiopian at Wonji, standard operation procedures activities for sugarcane fields, factors affecting sugarcane production, discussed related work done in this area and finally summarize with observed challenges and gap identified the in the review.

#### **2.2 Internet of Things**

Every day the Internet is everywhere over us. Basically, the Internet is a network of computers and all of them are part of the same network. IoT or the Internet of Things means a network of internet-connected objects that can use embedded sensors and computers to capture and share data. It basically means that a device with an ip address anywhere in the world can be connected to any other device with an ip address, anywhere in the world using the interconnected network of networks also called the internet [9]. The increasing demand for food consumption both in terms of quantity and quality has raised the need for intensification and industrialization of the agricultural sector. The "Internet of Things" (IoT) is a promising technology that has the potential to have many solutions to modernize agricultural sectors. Scientific researchers and research institutions, as well as the industry, are in a race trying to deliver more and more. IoT products to the agricultural business stakeholders, and, eventually, lay the foundations to have a clear role when IoT becomes a mainstream technology [10].

The Internet of Things (IoT) is formed by networking interconnections of everyday objects through configuring wireless networks of sensors, which send information to other objects

and to people. Using intelligent interfaces, the network is easily embedded into the global network, the network infrastructure varies depending on operability and common communication protocols where physical objects have own characteristics. IoT enables “smart objects” in our environment to be active participants in business and information processes where they are capable of recognizing events and changes in their surroundings, share information with other objects or people by exchanging data and react autonomously to the environmental events with or without direct human intervention [11].

The Internet of Things (IoT) is a technology where in a device can be used to monitor the function of a IoT device. The Internet of Things (IoT) is concerned with interconnecting interacting things that are installed in different locations that distant from each other. Internet of Things (IoT) is a type of network technology, which senses the information from different sensors and makes anything to join the Internet to exchange information [12].

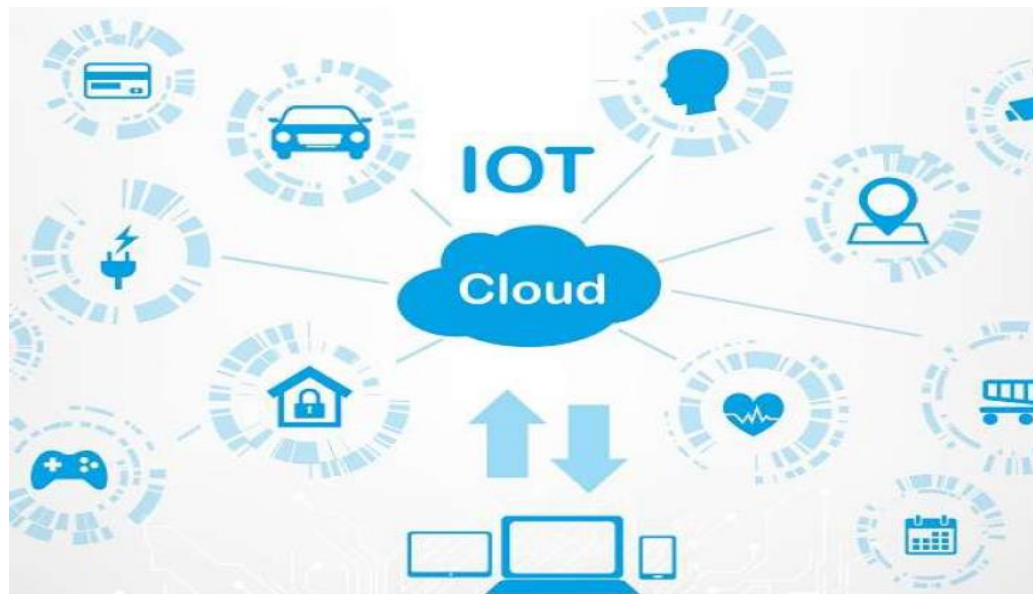

Figure 2.1: Description of IoT [13]

A successful implementation IoT requires the integration of IoT components. IoT for this reason can also be defined as ‘the ability of smart objects to communicate among each other and building networks of things’ [14]. The technologies used in implementation of IoT are:

- **Radio Frequency Identification (RFID):** It is used for automatic identification of anything they are attached acting as an electronic bar code and is in the design of microchips for wireless data communication.

- **Wireless Sensor Networks (WSN) Sensors:** The WSN network consists of hardware (consisting of power supply, processing units, sensor interfaces and transceiver units), communication stack (enables communication amongst the nodes), and middleware (platform independent sensor application development), secure data combination (for ensuring reliable data collected from sensors and for extending the lifetime of the network) [14]. The advancement of wireless sensor networks (WSN) was inspired by military applications, today, they comprise of appropriated free gadgets that utilizes the sensor to screen the physical conditions with their applications stretched out to the industrial infrastructure, robotization, wellbeing, activity, and numerous customer regions. Wireless sensor network is part of the IoT class [15].
- **Addressing Schemes:** The basic for development of IoT is that the uniform resource network (URN) that makes replicas of resources accessed through address (Uniform resource Locator). The connectivity flow of internet from users (high level) to sensors (low level) that is available (through URN) and accessible (through URL) [14].
- **Data Storage and Analytics:** The information created by IoT are to be stored and used for smart sensing using intelligence. To attain machine-driven decision-making, storage solutions based on cloud are getting common. Temporal machine learning strategies supported by algorithms, neural networks and alternative computing techniques are necessary for machine-driven conclusions [14].
- **Visualization:** This plays a key role in attracting and understanding the IoT revolution to a user. This allows interaction of the user with the environment through images, diagrams or animations to communicate the message [14].

### 2.2.1 Applications of IOT

So far, IoT Technology Application are known to be useful in changing the lives of people around the world. The experts to get benefits of this technology understanding and by using this technology. The various applications in IoT are creating more wonders in this real-time world. IoT application scenarios were identified and grouped into few domains, which includes Transportation, Smart Home, Smart City, Lifestyle, Retail, Agriculture, Smart Factory, Supply chain, Emergency, Health care, User interaction, Culture and tourism,

Environment and Energy. Some of the IoT applications are briefly explained in the following paragraphs [16].

**Transportation:** To make the transport service more accessible IoT technology provides an efficient service by making the surrounding machines sensor assisted and the machines connected through the internet. The IoT can play the important role in integration of communications, control, and information processing across various transportation. Application of the IoT extends to all aspects of transportation systems (i.e., the vehicle and the driver or user). Dynamic interaction between these components of a transport system enables inter and intra vehicular communication, smart traffic control, smart parking, electronic, logistic and fleet management, vehicle control and safety and road assistance [17]. Various vehicles can be monitored by means of a central control connected through the network. This also helps in managing the imports and exports of materials and goods. It also offers a live and integrative services for monitoring the delivery status indicating the location using GIS mapping. IoT could help in monitoring the traffic and gives the suggestions to take other lines [18].

**Environmental Monitoring:** The implementation of IoT in environmental observation are broad protection of environment, weather condition observation, protect water safety, seeds species selection and protection and business farm. In these applications, sensors find and live each data of environmental. The Environmental monitoring applications of the IoT typically use sensors to assist in environmental protection by monitoring the atmospheric situations. The physical devices connected to the Internet which are used as warning systems can also be used by emergency services to provide more effective aid [17]. Environmental monitoring applications typically utilize sensors to monitor the quality of air, water, and soil [19].

**Infrastructure Management:** IoT application in Infrastructure Management could observation and dominant operations of urban and rural infrastructures like bridges, railway tracks. The use of IoT to manage any occasions or changes in structural that may compromise safety and increase risk. Monitoring and control operations of rural infrastructures like bridges, railway track. It is a key application of the IoT. The IoT infrastructure can be used for monitoring any events or changes in structural conditions that

can compromise safety and increase risk. It can also be used for scheduling repair and maintenance activities in an efficient manner, by coordinating tasks between different service providers and users of these facilities. IoT devices can also be used to control critical infrastructure like bridges to provide access to ships. Usage of IoT devices for monitoring and operating infrastructure is likely to improve management and emergency response coordination, and quality of service, up-times and reduce costs of operation in all infrastructure related areas [17].

**Manufacturing:** In the IoT Application in manufacturing sector machines allow people to produce products without Human interfering through internet by the use of sensors. The IoT enables the quick manufacturing of new products and real –time optimization of manufacturing production and supply by using networking machinery, sensors and control systems together. IoT helps in digital control systems to automate process, to optimize the plant safety and security are interlinked with the IoT. Measurements, automated controls, plant optimization, health and safety management, and other functions are provided by large number of networked sensors. National science foundation established an industry/University Cooperative Research Center on intelligent maintenance systems (IMS). The vision is to achieve near-zero breakdown using IoT-based manufacturing. In future we can see the e-manufacturing plants and e-maintenance activities [17]. The embedding of tiny electronics into physical objects and the networking of them, make them “intelligent” and seamlessly integrated within the resulting cyber-physical infrastructure. Thus, IoT can bring the greatly enhanced horizontal integration of various manufacturing resources used in different stages of manufacturing processes, and vertical integration of them at different hierarchical system levels [20].

**Medical and health care:** Internet of Things (IoT)-enabled devices have created remote observance within the health care sector possible. IoT helps healthcare to improve existing features by supporting patient management, medical records management, medical emergency management, Treatment management and other facilities, thus increasing the quality of healthcare applications [21]. the patients safe and healthy and empowering physicians to deliver best care. IoT devices can be used to enable remote health monitoring and emergency notification systems. Some hospitals have begun implementing

smart beds that can detect when they are occupied and when the patient is attempting to get up [17].

**Home automation:** - IoT home automation is that the ability to regulate domestic appliances by electronically controlled, internet-connected systems. It should embody setting complicated heating and lighting systems ahead and setting alarms and residential security controls all connected by a central hub and pilotless by a mobile app through WiFi. Under the Home Automation we can control all electrical appliances from long distance through a mobile phone [22]. Home automation is the residential extension of building automation. It involves the control and automation of lighting, heating, ventilation, air conditioning (HVAC), and security, as well as home appliances such as washer/dryers, ovens or refrigerators/freezers. They use Wi-Fi for remote monitoring and are a part of the Internet of things [17].

**Energy management:** - What is IoT Energy Management? A method that features coming up with & management of your energy consumption patterns in service & industrial sectors. Our Energy management answer takes complete management of your energy information at elementary & granular level whereas reducing your energy prices. Energy management Integration of sensing and actuation systems, connected to the internet, is likely to optimize energy consumption. It is expected that IoT devices will be integrated into all forms of energy consuming devices and be able to communicate with power generation [17]. IoT provides a better way to monitor energy usages not only at the appliance-level but also at the grid level, house-level or even at the distribution level. Smart energy systems such as Meters & Smart Grids are installed at various organizations and houses to monitor energy consumption. This system is protected against losses such as damaged equipment, downtime, and injuries by detecting threats to system performance and stability of the equipment [23].

**Media, Entertainment:** - The IoT permits the enjoyment business to predict and perceive client behavior by analyzing the gathered information and inserting the proper content on the customer's wants through internet. Media, Entertainment Application of IoT in media causes to transfer data through cloud from one place to another place, IoT provides good communication between people through transfer the media one to another [17].



**Security:** - IoT for Security can be used as a security strategy and defense mechanism to prevent sites and attacks on IoT devices that are network-connected and intentionally designed for IoT devices. It also protects the user from attackers to supports by video and alarm signals. Security In modern lives there is a fear about thieves, by using IoT in home security devices, the security device is operated by a particular person from anywhere through cloud [17].

**Agriculture:** - IoT-based Agricultural application good farming can be done with the help of sensors like humidity, temperature, soil moisture etc.) to control the status of the crop, remotely monitor crop conditions and reducing costs and time. Agriculture By develop the agriculture machinery into smart devices causes control the water pumps and sprayers are controlled anywhere [17]. It will monitor Soil nutrition, Light, Humidity etc. and improve the green housing experience by automatic adjustment of temperature to maximize the production. Accurate watering and fertilization will help improving the water quality and saving the fertilizers respectively [23]. IoT can provide efficient and low-cost solutions to the collection of data. Weather, Water Scarcity, Soil fertility and Pesticides are the significant players in it [24].

### **2.2.1.1 Application Area of IoT in Agriculture**

By means of the Agricultural IoT for smart farming, farmers can control the field situations from anywhere using sensors (light, humidity, temperature, soil humidity, etc.), a microcontroller and an internet platform the crop area. IoT primarily based remote sensing utilizes sensors placed on the farms like weather stations for gathering information that is transmitted to analytical tool for analysis. Sensor's area unit devices sensitive to anomalies. Farmers will monitor the crops from analytical dashboard and take action supported insights. IoT is gradually becoming the important stockholder of the industry due to its reliability, efficiency and smart working principle. With help of other emerging technologies such as sensor, micro-controller and actuator [25]. The following areas to implements IoT application area in agriculture sectors.

### **i. Agricultural field Monitoring**

IoT-based Smart Farming strengthens the entire agricultural system by real-time field monitoring. The Internet of Things in Agriculture not only saves farmers' time with the aid of sensors and interconnectivity, but also decreases the extravagant use of resources such as water and manpower different factors such as humidity, temperature, soil, etc. The traditional methods of monitoring agricultural fields are very time consuming and have lack of accurate field monitoring. The advantages of technology in water saving and labor-saving are initiated using sensors that work automatically as they are programmed as the threshold's values. concept of modernization of agriculture is simple, affordable and operable [26]. The sensitive parameters of the agricultural fields cannot be monitored with acceptable accuracy. Plants diseases are very important factor and have direct impact on agriculture product and it is very difficult to diagnose them manually. IoT technology is one of the interesting aspects of the IoT smart framework. To monitoring the agricultural products in automatic, calculate the product samples and the quality measure features can easily be implemented by the help of smart monitoring of the precision agriculture framework [25].

### **ii. Green House Monitoring**

The agricultural revolution creating smart greenhouse technology to use sensors and actuators to monitoring and control systems to control climate condition of the plant that optimize the conditions of growth and automate the growing process. Agriculture science is one of the most important area of focus in these days. The parameters include temperature, humidity, soil monitoring and evaporation rate of water etc. These physical parameters can be measured with implementation of the microcontroller based smart devices having integration of different types of tiny sensors. Sensors are smart devices used to measure the physical parameters of the environment [25]. Automating a greenhouse envisages monitoring and controlling of the climatic parameters which directly or indirectly govern the plant growth and hence their produce plant growth and hence their produce [27].

### **iii. Agricultural Drones**

Agriculture drones can see the plants reflect to check green light and light from near infrared spectroscopy. The drone's data helps to create multispectral images to monitor the health of crops. IoT with drone technology has become very popular in modern technology, which can monitor and regulate the activities of any environment. In agricultural science, the drone technology can be used to monitor the activities of the agricultural crops. The drone technology brought revolutionary changes in the agricultural monitoring activities with accuracy and frequent updates which is difficult to manage by using traditional methods. A number of activities can be monitored using the drone technology such as spraying the plants with desired number of pesticides, and monitoring the theft of the crops from the premises of the agricultural farm, to name a few [25].

### **iv. Livestock Monitoring**

Monitoring of the livestock is used to monitor location and health parameters such as temperature, blood pressure measurement and the environmental conditions of the animal farm such as temperature, humidity, nitrogen and carbon dioxide of the farm area where animals are kept. The herd area can be monitored easily using the sensor technology and IoT has made it easy to perform real time monitoring time-to-time [25]. The Internet of Things has progressed in livestock management, helping farmers to embed internet-connected sensors on their animals without causing them pain. A primary advantage for monitoring livestock is to help farmers track their cattle, their temperature, humidity, heartbeat which will help to manage the livestock in an easier and efficient manner [28].

### **v. Smart Irrigation Control**

The Smart Irrigation Control System is an IoT based tools capable of measure the soil moisture and climatic conditions to automate the irrigation process. The sensor data will also be shown on the graphical form visualization cloud platform. The time management of the water pouring in the field is very important for the soil. This gives the need of IoT to give the automated status of the soil. The soil update and water level measuring are important for the automated water supply management [25]. A smart irrigation management system is responsible for predicting the water needs of the crops based on collected data and actuating

the water flow according to the predicted needs without the involvement of human operators. It monitors various soil, water body, plants, and microclimate parameters using distributed sensors. The specific irrigation method (e.g., flooding, spray, drip and nebulizer) has impact on the decision of how to monitor effectively the water body as well as the actuation method [29]. Improving irrigation efficiency can contribute greatly to reducing production costs, making the industry more competitive and sustainable. Through proper irrigation, average crop yields can be maintained (or increased) while minimizing environmental impacts caused by excess applied water and subsequent agrichemical leaching. Recent technological advances have made soil water sensors available for efficient and automatic operation of irrigation systems. Automatic soil water sensor-based irrigation seeks to maintain a desired soil water range in the root zone that is optimal for the plant's growth [30].

#### **vi. Agriculture Warehouse Monitoring**

The agricultural Warehouse monitoring is Automation has become an inseparable component of today, for which IoT has emerged as an exceptional platform that provides connectivity between different sensors, controllers and the internet that allows for far-flung monitoring and control of automation-related environments in the Warehouse. In agriculture water monitoring, IoT has brought the concept of smart warehouse monitoring. IoT enhanced this capability with a very rapid and fast threat detection. Agricultural warehouse can be monitored real time with the implementation of the human detection sensors, temperature status of the warehouse by the temperature sensors, and other important parameters related to the staff monitoring and owner awareness related to the warehouse status [25]. The role of ware housing and storage has change drastically and there are demand and expectation in today's industry. The main purpose of the monitoring system is to obtain temperature, humidity, moisture and light sensor readings from the storage to be relayed to a remote user over the internet [31].

#### **vii. Soil Monitoring**

IoT based soil monitoring uses technology to enable farmers and producers to optimize yield, reduce disease and resource optimization. Soil temperature, volumetric water content, photosynthetic radiation, soil water potential and soil oxygen levels can be measured by IoT sensors. Monitoring of soil moisture in different areas of a farm can help in overall irrigation

management. Different crops require different irrigation strategies and using real time data of soil moisture a farmer can increase yield by maintaining an optimal soil moisture for a specific crop [32]. Soil is a key component for the agricultural crops for monitoring the soil, IoT made it easy to control and coordinate the changes in soil. Nitrogen (N), CO<sub>2</sub> and other important parameters can be monitored and updated to the cloud in real time. A robust recommendation system can be designed for the betterment of the soil fertilization [25].

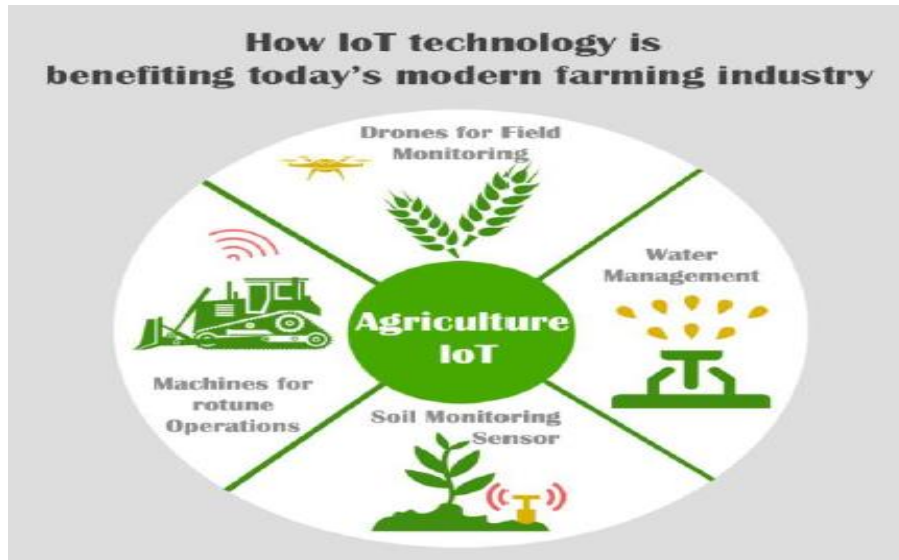

Figure 2.2: Application Area of IoT In Agriculture [13]

### 2.2.2 Internet of Things Architecture

IoT needs an open architecture to maximize interoperability among distributed and heterogeneous systems. Architecture standards should consist of well-defined interfaces and protocols, abstract data models and neutral technologies, such as Extensible Markup Language (XML), to support a variety of programming languages and operating systems [11].

The IoT architecture should be designed to be resilient to disruption of the physical network and ensure the nodes use various communication protocols to connect to the IoT since they may have intermittent connectivity. IoT nodes should form peer networks with other nodes through a decentralized approach to the architecture with support for discovery and peer networking.

IoT requires prototyping of embedded devices such as the Arduino Chip, which combine the

RAM, processor, networking and storage capabilities onto a single chip which makes them more specialized. The chip also runs on low power and is programmable to tailor it to developer specifications [33].

Due to the large volumes of data that will be generated, there is need for routing, processing and storage of the information remotely in the cloud. This will enable effective caching, synchronization, updates and data flows in the architecture.

### **2.2.3 Communication framework Structure of IoT**

Internet of Things technology is mainly applied in planting as well as the preservation of agricultural products, therefore grower can collect the data of crop growing environment, growing states during these processes through the wireless sensor technology. First, the data will be sent to management center through the network transmission, second the data will be big then analysis, and remotely control the growth of the plant. Internet of Things includes three layers: perception layer, transport layer and application layer [34]. Internet of Things includes three layers: perception layer, transport layer and application layer.

- **Perception layer** realizes communication, energy, environmental perception mainly through sensors, video, RFID, which are mainly used for data acquisition and environmental monitoring;
- **Transport layer** sends the collected data of sensor back to background data management center mainly through the application of WLAN network, 4G networks, etc.;

- **Application layer** implements analysis and summary to data through big data and cloud computing, to realize detection, data storage, data management, and automation control. IoT applications is found in application layer which requires to support and operate the applications.

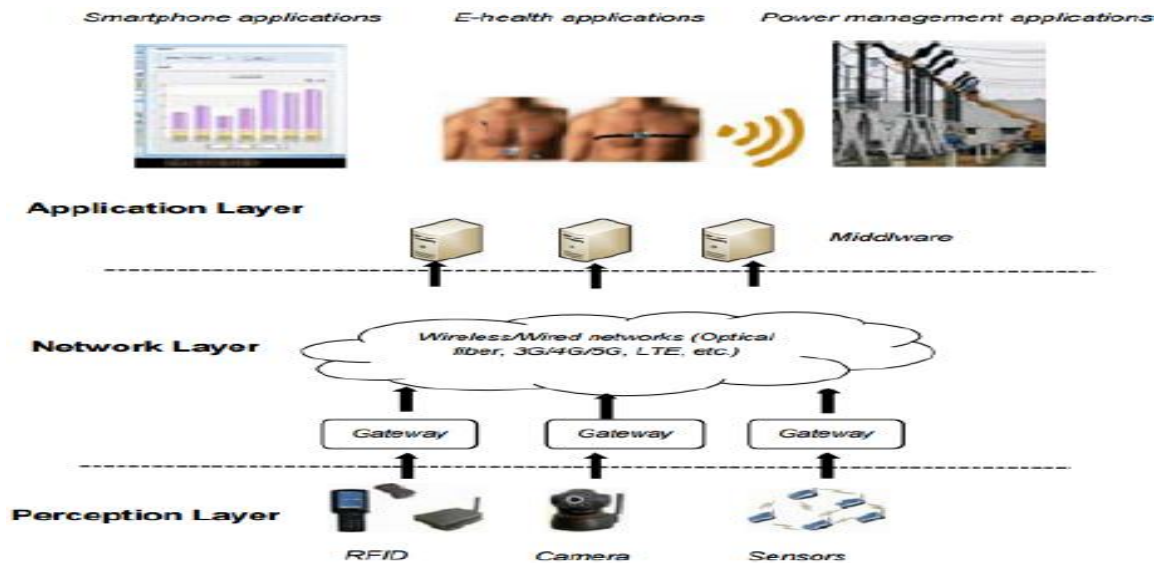

Figure 2.3: The three –layer IoT architecture [35]

### 2.3 Sugarcane Production in Ethiopia

Ethiopia is gifted with large areas of suitable low lands, rivers and conducive climate for sugar cane growth. The climate and soil types in the country have both proven to be highly conducive for sugar cane growth and productivity. Various pre- feasibility and feasibility studies of sugar projects conducted by the Ethiopian Sugar Industry Support Center Share Company (ESISC) have indicated that many potential sites at the main river basins are suitable for sugar cane plantation. These include 303,500 hectares of already identified suitable net areas in 7 sites. However, the total area developed for the production of sugar cane in the country is only about 8% of the total identified suitable areas [36]. Experiences of existing sugar factories show that because of the suitable soil, adequate water and conducive climate, an average sugar cane production per hectare per month of the land under irrigation is very high as compared to other countries i.e.,9-11 tons against 6-8 tons. This

would make Ethiopia a very attractive location for private investors to invest in the production and processing of sugar cane [36].

### **2.3.1 Standard Operating Procedures for Sugarcane Production at Wonj/Shoa Sugar Estate**

Standard Operating Procedures are sets of instructions having the force of a directive, covering those features of operations which lend themselves to a definite or standardized procedure without lack of effectiveness. Therefore, it is important to follow the established procedures to solve these problems. Standard production practices should be defined first to ensure proper field management in sugarcane production at sustained basis [37]. Work standard can be defined as the current single best way to complete an activity with the highest degrees of safety and efficiency, which produces consistent and high-quality outcomes. In this regard, all of the former existing sugar estates have some sort of sugarcane production manual, which was prepared some years back [37]. Some modifications have been made to the operating procedures and adopted to the new sugar factories (Tendaho, Kesseme and Arjo-Dedessa) and projects (Kuraz, Beles, and Welkayit). In recent years, rapid decline in cane productivity is being observed in some of the existing sugar estates. It is believed that this decline in yield of sugarcane is caused largely due to inconsistent and below standard field management practices. These inconsistent field management practices resulted from a number of factors such as lack of well-organized and standardized operating procedures, and lack of updated practices based on research findings and experiences of other sugarcane producing countries. This standard operating procedure clearly states the unit operations and cultural practices to be applied for the successful production of sugar cane [37]. The importance of a standardized work procedure for cane production practices is not questionable even though the ultimate result will depend on quality of the standards, proper implementation of the standards, and availing inputs timely at the required quality and quantity [37]. Thus, the document has been prepared with the objective of setting standard operating procedures for sugarcane production and thereby improving productivity and profitability sustainably [37]. Doing the standard operation procedures (SOP) of sugarcane in the fields will increase the productivity of sugarcane. To Increase the production of sugarcane solving the availability of sugar in the market and reducing the amount of sugar imported and increase



export sugar in the foreign market. finally, to attain the millennium goal for our country for covering the sugar in the market.

### **2.3.2 Factors affecting Productivity of sugarcane Production**

Factors affecting sugarcane production are decomposed as socio-economic factors and environmental factors. The socio-economic factors such as farm size, labor, amount of basal fertilizer and urea applied, amount of chemicals used, age of the farmer, gender of the farmer, level of education, marital status, non-farm income, extension support and environmental factors that include drought (variability in climate change) and soil fertility and degradation. In [38] potential impacts are grouped into impact categories such as economic, socio-economic, natural resource and ecological impacts.

The key reasons responsible for the poor production of sugarcane and for illustrating the different production processes for sugarcane in the current farming method. It also highlights the scope for improved management practices and the identification of technical and socio-economic factors which restrict the increase in the production of sugarcane in the study area. The major concern is to assist in the assessment of incentives for sugarcane farmers, as incentives for any crop play an important role in its growth and delivery of profits from its production. The efforts have been made to describe the management practices, input use, sugarcane varieties, insect-pests and disease problems [39].

## **2.4 Related Works**

The literature review on IoT and more specifically its implementation in the agricultural sector. It provides an overview of previous research on the use of technology in Agriculture specifically Internet of Things technologies. It looks at a couple of Internet of Things technologies that are been researched into and currently making agriculture less difficult and increasing farm yield. The use of IoT for Improving Sugarcane Productivity has not been extensively studied. This Chapter covers some of the existing proposals that focus on Improving Sugarcane Productivity using IoT.

In [3] this paper said, deals with IoT that can be used to improve cultivation of food crops, as lots of research work is going on to monitor the effective food crop cycle, since from the start

to till harvesting the farmers are facing very difficult for better yielding of food crops. The use of remote sensing is necessary, as the monitoring of agricultural activities faces special problems not common to other economic sectors. The production depends on the physical landscape (e.g., soil type), as well as climatic driving variables and agricultural management practices. All variables are highly variable in space and time.

Finally, he proposed on current agricultural approaches so that continuous sensing and monitoring of crops by convergence of sensors with IoT and making farmers to aware about crops growth, harvest time periodically and in turn making high productivity of crops and also ensuring correct delivery of products to end consumers at right place and right time.

Overall, the work can help researchers as a starting point. But the problem here is that there is no clearly stated procedure to be taken such as the number of sensors to be deployed and which kinds remote sensing technology widely used for Agronomist. The author also did not explain on how data will collect and transferred whether a WiFi will be used or other mechanisms and how and where the data to store for analysis to decision-making. Overall, it lacks clear explanation approaches the author has used and no experimental results are provided.

In [25] this paper said, that the traditional methods of monitoring agricultural fields are very time consuming and have lack of accurate field monitoring. The sensitive parameters of the agricultural fields cannot be monitored with acceptable accuracy. Plant's diseases are very important factor and have direct impact on agriculture product and it is very difficult to diagnose them manually. IoT technology is one of the interesting aspects of the IoT smart farm work. The automated calculation of the product samples and the quality measure features can easily be implemented by the help of smart monitoring of the precision agriculture farm work. IoT technology, with emerging role of the related fields, have brought a revolution in automation of the real life. Agriculture science is one of the most important area of focus in these days.

This study proposed that Automation replaced the traditional frameworks is another alternative for enhancement in any field; it diminishes human exertion, save time and increase the precision of the framework. Automation of water irrigation system, IoT innovation

achieves such objective. For sugarcane crop irrigation required within 5 to 20 days as per conventional irrigation method on the basis crop region. Flooding till the prerequisite will be fulfilled, and gives the better alternative for water saving.

The gap of this research papers is to increase the productivity of sugarcane, the researchers Said that sugarcane should be watered gives for 5 to 20 days with normal and traditional way, but this is not cost-effective and also decreased the productivity of sugarcane. In addition to that which kinds of evidence to gives watering 5 to 20 days for a crop. The researchers are also not clearing states the methodology and which kinds of technologies to be used for the above proposed solution.

In [34] this paper said, relying on the Internet of things technology, has designed and implemented a set of sugarcane growth monitoring system according to the growth characteristics of sugarcane crops, this system has passed the test, and results showed that it can effectively monitor growing environment of sugarcane, such as temperature, humidity, crop plant height, thus realize the whole process management of agricultural automation.

This paper proposed the designed and implemented a set of sugarcane growth monitoring system based on RIFD and ZigBee, this system can be used for network monitoring through Internet network monitoring, and implement real-time monitoring by relying on the Internet of Things technology and video image processing technology. Internet of Things includes three layers: perception layer, transport layer and application layer. Perception layer realizes communication, energy, environmental perception mainly through sensors, video, RFID, which are mainly used for data acquisition and environmental monitoring; transport layer sends the collected data of sensor back to background data management center mainly through the application of WLAN network, 4G networks, etc.; application layer implements analysis and summary to data through big data and cloud computing, to realize detection, data storage, data management, and automation control. This experiment has selected one month from three periods of sugarcane growing to do real-time monitoring data collection. The mainly data collected in the system include temperature and humidity, sunshine, CO<sub>2</sub>, as well as to plant growth height. The actual measured plant height is analyzed with video measurement analysis data by using the portable measuring instrument, Monitoring and management system needs to use big data analysis technology to do data analysis more

efficiently due to long test period, large amount of data. The effective image information can be captured through double CCD camera.

The problem of this research paper shows that IoT for Sugarcane growth monitoring and cost reduction does not reflect the productivity of sugarcane in terms of cane growth. How to communicate to each other's and how to put the real data in storage for the purpose of Analyzing to decision making for Agronomist.

In [40] this study said, an attempt Analyze the technical efficiency of Sugarcane production and to identify factors affecting level of technical efficiency in this study, an attempt was made to measure the technical efficiency of sugarcane production at Wonji Sugarcane Estate Farm and also study was conducted to examine possible reasons for low productive performance of sugarcane production by using cross sectional data gathered from Wonji/Shoa Estate Farm and analyzing its technical efficiency. Some Plot units had a slightly higher technical efficiency than other plot units did. Technical inefficiency effects are modeled as a function of area, cane age, cane variety, cane type (ratoon) and soil type. The researchers proposed the mean technical efficiency of Wonji sugarcane Estate Plot found in this study is 77% whereas the maximum and minimum technical efficiency is 96 % and 10 % respectively. Thus, there is a need to increase the technical efficiency by 23% by adopting the following points: -

- The pump irrigation type of sugarcane watering system is highly prone to suffer from hydroelectric power fluctuation and as well it is time taking to access all over plot units if once interrupted because of hydroelectric power break which have a significant impact on reducing the technical efficiency of sugar cane yield. There for enough generators should be available in such situations, in regard to the water loss from the canals.
- Rehabilitating of the canal system is necessary before lining with lining materials. After that lining of selected canals with any lining material is preferable. The work must be started from upper reach of the scheme and should go down to smaller canals following topography and discharge capacities. Besides, repairing of water controlling structures at each junction along the way should be carried out simultaneously.

The researchers the methods to used Maximum likelihood estimate of technical efficiency was obtained from half-normal model which was supposed to describe the data adequately and the researcher's analysis was employed both descriptive and econometric methods. The final output of the total production of sugarcane production varies from one plot to another plot. By major determinant land, Equipment, Labor, Material, Cane variety, Cane Age, Soil Type and Cane Type (Ratooning).

The limitation here is not just the problems mentioned above, but also the reasons for the decline in sugarcane productivity not only above factors. In particular, there are factors that can increase soil productivity, especially in terms of irrigation of the cane and identification of soil moisture content, as well as environmental factors.

In [41] this Study said, the field section, various sensors are deployed in the field like temperature sensor, moisture sensor, ultrasonic sensor and humidity sensor. The data collected from these sensors are connected to the Arduino UNO. In control section, the received data is verified with the threshold values. If moisture level is low then Arduino switches on a water pump to provide water to the plant. Water pump gets automatically off when system finds enough moisture in the soil and a message is sent to the user via IOT module, updating the status of water pump and soil moisture. Thus, the system is useful to monitor the parameters for agriculture such as temperature, humidity, moisture, leaf growth, spray the water and pesticides through the motor pump via IOT module. The system reduces the manual work, manpower. Crops Damage caused by predators is reduced and also be used to increase the productivity. IoT sensors capable of providing farmers with information about crop yields, pest infestation and soil nutrition are invaluable to production and offer the precise data.

The study is not identifying the problem address efficiently, which kinds of crops to uses the proposed solution. The way to clarifying communicate the sensors and the main controller is another problem of the proposed solution. This paper Saied that if moisture level is low then Arduino switches on a water pump to provide water to the plant. Water pump gets automatically off when system finds enough moisture in the soil. This is not clear by which kinds of Analysis data to give the water is low not to sets parameter level of the environmental and moisture level, and the irrigation depth and irrigation interval and where is the privaous

data put for analysis with standard parameters. Finally, the summary can be described in the table 2.1.

Table 2.1: Summary of related works

<b>Researcher</b>	<b>Title</b>	<b>Main Work</b>	<b>Research Gap</b>
Pavankumar, Rajeshwari, Nagaraj, Jagadeesh and Kiran [3]	Importance of IoT for Smart Agriculture	The use of remote sensing is important because the monitoring of agricultural activities is faced with unique difficulties that are not familiar to other sectors of the economy.	The problem here is that there is no clearly stated procedure to be taken such as the number of sensors to be deployed and which kinds remote sensing technology widely used for Agronomist.
Azeem, Muhammad, Mushtaque, Mairaj and Nabi [25]	Review IoT Application and challenges in Agro-Industry	The traditional methods of monitoring agricultural fields are very time consuming and have lack of accurate field monitoring	not clearing states, the methodology and which kinds of technologies to be used for the above proposed solution.
Li, Ling, Tian and Zheng Shiyong [34]	Design and Implementation of Sugarcane Growth Monitoring System based on RFID and ZigBee	Internet of things technology, has designed and implemented a set of sugarcane growth monitoring system according to the growth characteristics of sugarcane crops	This research paper shows that IoT for Sugarcane growth monitoring and cost reduction does not reflect the productivity of sugarcane in terms of cane growth
Bereket Ekubay [40]	Analysis of Technical Efficiency of Sugar Cane	Analyze the technical efficiency of Sugarcane production and to	The limitation here is not just the problems mentioned

	Production in Ethiopia	identify factors affecting level of technical efficiency in this study	
Rajakumar, Saroja, Shunmugapriya and Maheswari [41]	IoT Based Smart Agricultural Monitoring System	Study the field section, various sensors are deployed in the field like temperature sensor, moisture sensor, ultrasonic sensor and humidity sensor	The gap of this paper is not identifying the problem address efficiently, which kinds of crops to uses the proposed solution. The way to clarifying communicate the sensors and the main controller is another problem of the proposed solution.

To summarizing review of the related works, we addressed a major gap in the current literature and the review started by exploring the concept of IoT with its technology and architecture and also discussed about sugarcane. This shows that there is a gap in the improve sugarcane production sector. In the review one of the challenges identified in the sugarcane sector in the country is lack of automated technologies to manages and control production sugarcane plants and adoption of recent technologies in this sector. IoT for Sugarcane growth monitoring and cost reduction does not reflect the productivity of sugarcane in terms of cane growth. Seeing this as a gap and to fill by increase sugarcane production by using IoT technology and to identify the factors addresses like environmental factors temperature, humidity and soil moisture level plays a major role for the growth of cane plant with improve sugarcane production can be shown. In addition, we have been able to solve this problem and the way to increase sugarcane productivity and prevent water wastage by irrigating as well as to give the water for a plant with the right time. Thus, there was a need to design an IoT based technologies to manage and improve sugarcane production. In the next chapter discussed the methodology used in this research to fill the gap identified in the study.

## **CHAPTER THREE**

### **RESEARCH METHODOLOGY**

#### **3.1 Overview**

This chapter details with the overall methodologies that were used in the study. This is organized into areas of the study, research design, data collection methods, sampling procedures, method of data analysis, evaluation criteria and ethical concerns.

#### **3.2 Description of the Study Area**

Wonji sugar factory is found at Oromia Regional State near Nazareth City at 110 Kilo Meters from Addis Ababa [42]. Commencing production in 1954 it is the oldest and the pioneer in the history of Ethiopia's Sugar industry and Shoa Sugar Factory constructed in 1962 is the second oldest and both, being obsolete, have stopped production since July, 2012 and July, 2013 respectively. The two factories constructed by the Holland Company known as H.V.A had a capacity of producing 750,000 quintals of sugar a year. The sugarcane plantation land of these two factories was 7,000 hectares out of which 1,000 had been planted by out growers.

In a bid to replace these two oldest factories with a new and modern one, an expansion project had been carried out both in the cane cultivation field and the factory since 2010. And, the factory plant expansion project has come into its completion in July, 2013. Accordingly, the newly built and modern Wonji/Shoa Sugar Factory has currently a design capacity of crushing 6,250 tons of cane a day and producing over 174,000 tons of sugar per annum which with further expansion will reach up to 12,500 TCD maximizing its production to 220,700 tons of sugar a year. The new ethanol plant planned to be built, will have a capacity of producing 12,800-meter cube. The Factory is currently contributing 20 megawatt electric powers to the national grid in addition to satisfying its own demand that is around 11 megawatts.

Its agricultural expansion project is currently being carried out around the areas known as Wakie Tiyo, Welenchiti and North Dodota areas. The factory, with the help of this



agricultural expansion project, will have 16,000 hectares of sugarcane plantation field in total. The total cane cultivation field of the factory has currently reached 12,800 hectares and, the 7,000 hectares of the factory’s sugarcane field cultivated with the agricultural expansion project is owned by out grower farmers of the surrounding area. There are 32 Sugarcane out growers’ associations, which in total have 9,100 member farmers. The Factory, beyond supplying the farmers with selected seeds, and rendering professional as well as technical support to them, has made irrigable land available to all [42].

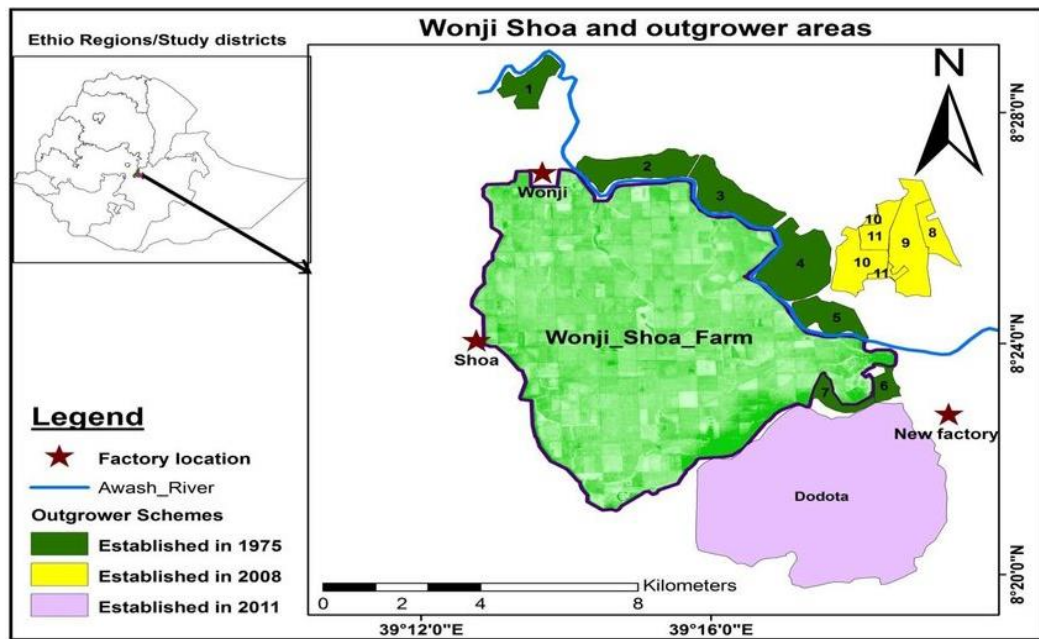

Figure 3.1: Wonji/Shoa Sugar Factory Sugarcane Plantation Area

### 3.3 Research Design

An applied research design was used in this study. The research design included identifying the practical problem that is set on providing practical solutions in the right directions, build a prototype and test whether the prototype meets desired functions with respect improving sugarcane productivity.

Moreover, the researcher used Structured Systems Analysis and Design Method (SSADM) for a rigorous system analysis, design and development. It involved logical data, data flow and entity event modelling in a sub system.

### **3.4 Research Methodology**

#### **3.4.1 Target Population**

The target population allocated with researchers for sugarcane plantation and the target population was employees works in Ethiopian Sugar Corporation Research and Development Center. In the sugarcane research department twenty-three (23) employees who are distributed as shown in table 3-1.

Table 3.1: Target Population

<b>Role of Employee Number</b>	<b>Number</b>
Managers	2
Employees	21
Total	23

#### **3.4.2 Sampling Design**

The sample that was used in this research was twenty-three (23) employee to involve. This organized the entire population who work in Ethiopian Sugar Corporation research center at Wonji and Wonji/Shoa sugar factories plantation and irrigation office for sampling survey the entire population. The techniques used to this research is non-Probability sampling techniques that is used to answers the research questions and objectives depends on research design [43]. In order to generalize from a random sample and avoid sampling errors or biases, a random sample needs to be of adequate size. What is acceptable relies on many problems that sometimes annoy individuals conducting surveys for the first time. This is because what is important here is not the proportion of the sampled test population, but the absolute size of the chosen sample relative to the population's complexity, the researcher's goals, and the forms of statistical manipulation to be used in data analysis. While the larger the sample the lesser the likelihood that findings will be biased does hold, diminishing returns can quickly

set in when samples get over a specific size which need to be balanced against the researcher's resources [43].

### **3.4.3 Methods of Data Collection and Tools**

The researcher made use of both primary and secondary data. Primary data was useful in getting from the first-hand. This data is collected from Filed visit and face-to-face interviews were used to collect data from Agronomist, researchers and the concerning bodies of the Sugarcane plantation areas. The main interviews were preparing a small number of semi-structured interview questions to more than ten respondents were asked about a given topic. This semi-structured interview is flexibility to the analysis.

Secondary data was used to understand IoT technologies that means the data collects from the sensors data and selecting one that was appropriate to design an IoT system that would enable recording of environmental conditions and the soil condition. finally analyze data and display to various techniques for end-users such as Agronomist. Visio 2010 was used for designing the system architecture.

### **3.4.4 Method of Data Analysis**

Thematic coding and thematic analysis were used to analyze the gathered data. Thematic analysis is an established method of organizing qualitative data and has good potential in capturing knowledge and experienced of workers and experts. Thematic analysis (TA) is a popular and foundational method of analyzing qualitative policy data. It is concerned with the identification and analysis of patterns of meaning (themes) and constitutes a widely applicable, cost-effective and flexible tool for exploratory research [44]. TA is particularly suitable for analyzing experiences, perceptions and understandings. It can be used to analyses a large variety of qualitative data and is a flexible method which can be applied within various theoretical frameworks. TA is also applicable independently of any initial theory and can be used for purely inductive research. Furthermore, it is suitable for the analysis of small, medium-sized and even large data sets [44]. The interviews are using for thematic analysis its usefulness to see at and understand the experience of farmers in terms of environmental conditions and the importance of sugarcane production.

### **3.4.5 System Evaluation**

To evaluate the system, a survey will be conducted to gather the user evaluation about the system. For the next demonstrate the prototype in the form of presentation and preparing the system usability test questionnaires about the system and collect the feedback to simplicity, usability, functionality and security.

## **CHAPTER FOUR**

### **REQUIREMENTS ANALYSIS AND DESIGN**

#### **4.1 Overview**

This chapter discussed the requirement analysis and design to develop the proposed prototype, which includes requirement analysis, comparatively evaluate the solution with respect to other similar solutions. in this section discussed the enhanced sugarcane production and the challenge faced with the proposed system overview. In requirement specification discussed hardware, software and platform used in the study. Finally discussed system design with the proposed system architecture, sub-system decomposition and sequence diagram for the proposed system.

#### **4.2 Requirement Analysis**

For requirement analysis, secondary data sources were collected from various sources documents and literature. Secondary data were obtained from existing framework, research articles, journal, conference papers, manuals and reports. In order to get data on measurements and, used technologies, challenges facing in current approach, and also to get data their level of awareness, factors affecting sugarcane Production and challenges faced in sugarcane Production.

##### **4.2.1 Factors Affecting Sugarcane Production**

Sugarcane productivity is the mechanism that results in sugarcane harvested in a timely manner by conducting various activities in the region. The different functions of the sector and the minimal climate of the environmental variables are among the factors that decrease productivity. Our country's major factors in the development of sugar cane rely on natural resources such as rainfall, drought stress and forest. Advanced agronomic checking including the growth of sugarcane varieties, planting time and methods, soil preparation, insect pest disease control, nutrients of the soil and water management seem to be very promising

measures for high sugarcane yield. There is a factor that affects decline the production of sugarcane in country. Some major factors are:

- **Water:** the lack of water is decreased of sugarcane plant yield production in our country. Sugarcane needs the larger amount of irrigation water than the opposite crops to achieve its maturity. Drought may be a major abiotic stress that affects crop productivity and exerts some visible symptoms on sugarcane.
- **Cane Variety:** The next main limit is inaccessibility of latest high seeds varieties frost free, tolerant to salinity and drought and proof against insect tormentor diseases varieties. The majority of the varieties developed in abroad are adapted in the country have deteriorated yield and sugar recovery. Some sugarcane varieties are developed through fuzz are very promising in the different agro-ecological parts of country.
- **Soil:** the soil is salty and alkaline the sugarcane is more sensitive to thus factors. The soils of southern part of country environmentally suitable for high cane yield and sugar recovery than the other parts of country, have high PH ranges (7.5 to 9.2).
- **Temperature:** The best ranges of temperature vary for different stages of crop, for good germination the temperature will required in between 32-38°C. Temperature above the 38°C it not only reduces the germination but also effect on vegetative growth, due to reduction in photosynthetic rates and increase in respiration. Ripening period, require low temperature in the range of 12-14°C reduces vegetative growth rate and enrichment of sucrose in the cane. Temperature below 5°C and above 35°C, not favorable for young leaves and buds. The high temperature may enhance the diseases and change the sucrose content into fructose and glucose and photorespiration may reduce accumulation of sugar.
- **Humidity and wind:** have relatively less management over sugarcane plant, however, an effect to a large extent just in case of extremes. Up to 80-85% humidity and warm weather conditions favor the rapid growth of the cane. In ripening phase, a moderate humidity with limited water supply is favorable. Similarly, wind has no harm to plant until it reaches to a velocity capable of breakage of cane or damage to leaves. The high velocity may be harmful in initial stage of plant growth. The long duration high velocity wind will result to loss of moisture. Broadly, two different sets of climatic parameters are required in the life cycle of the plant. The optimal rainfall seasons, long duration of bright sunshine and high humidity season is a good condition of production of sugarcane.

The change in environmental factors will have to be undesirable effect on sugarcane production. Though rise in temperature have still found low effect on decline of yield of sugarcane. But it will bring the changes in other factors like rainfall. Cultivation of sugarcane requires a thorough study of the soil and climatic conditions of the region which may vary as per the temperature of the region.

#### **4.2.2 Challenges faced in sugarcane Production**

The second objective was to identify the challenges faced in sugarcane Production in WSSF. The document analysis includes previous study done in the sugarcane that are found in Wonji. In the following section discussed the challenge faced in sugarcane production in Wonji:

##### **4.2.2.1 Problems with selection of the sugarcane varieties**

The choice of the sugarcane variety to be planted is the most important decision among the output and quality factors of sugarcane. it is providing the foundation of other technology for the production and processing of raw materials thus providing an extensive improvement in industrial productivity without an increase in production costs. The sugarcane varieties should exhibit desirable characteristics such as high yield, high sugar content, reshooting ability and pest and disease resistance. The moment one selects one variety to be cultivated, its characteristics and adaptation to the climate must be noted otherwise, the capacity for development and efficiency will be undermined. The right choice of sugarcane variety for cultivation is not a simple task because, in addition to the interaction of biotic, abiotic, regulatory, and economic influences, it depends on a host of fundamental knowledge relevant to agronomic and industrial factors.

##### **4.2.2.2 Irrigation Management in Sugarcane**

Sugarcane is one of the most water-intensive crops, and the availability of water is one of the major factors influencing its development. Sugarcane yields can decrease by up to 70 percent under drought conditions, according to studies. Climate change will increase the rate of evapotranspiration and decrease the availability of water in the soil and, thus, the need for irrigation in the production of sugar cane is increasing. The frequency of irrigation would depend on the texture of the soil and the depth of the root system, which defines the readily

available water in the soil. Scheduling of irrigation refers to the quantity and duration of water application. Based on evapotranspiration, the daily water demand can be determined. In the Wonji sugar factory, water is consumed in 20 to 25 days. But when I see this as a problem, it is impossible to know how much water has reached the cane and when to drink water. Finally, if we can improve our water use, sugarcane production will increase and reduce the costs.

#### **4.2.2.3 Absences of automated technologies**

A study done in sugarcane production show that, the main challenges of sugarcane in WSSF is lack of monitoring and controlling environmental conditions, lack of quality water sources, poor watering, species selection, pests and diseases and also lack of training on appropriate technological advancements in sugarcane Sectors.

#### **4.2.3 Comparison with other existing solution**

Some improvements have been made with the help of technology to increase sugarcane production in particularly irrigation of water and land preparation. I compare what they did improving production of sugarcane relatives to technology;

As a solution a researcher to give an answer to increase sugarcane productivity. With the help of the right farming technology, it is possible to increase the productivity of sugarcane by cultivating and adjusting the GPS technology of plowing, adjusting and laying the ground. so that water can reach the soil properly. More and more operations in sugarcane production are being carried out with the assistance of GPS technology [45]. The use of GPS technologies is to monitor or regulate the location of agricultural machinery in the field. Applications of GPS technology in sugarcane production include the following activities such as Surveying, Land preparation, Land forming etc. [45] GPS technology is currently in use in sugarcane production and the number of applications is on the increase as the technology improves and costs are reduced. In addition, sugarcane is expanding into areas that are more marginal where the need for precision approaches to farming will be required to maximize the returns from the land.

Traditionally, [46] most sugarcane farming systems used surface (specifically furrow) irrigation system because of its simplicity and low cost. But the increasing cost of energy and labor and the increasing demand for scarce water resources has led to greater adoption of



overhead or drip irrigation methods. However, furrow irrigation is still the major method used worldwide. Subsurface drip irrigation enhances growth and yield of sugarcane, not only through the precise application of the right amount of water, but also by maintaining adequate aeration of the root zone. Further, [46] it promotes the effectiveness of applied fertilizers by minimizing losses through processes such as denitrification.

Furrow irrigation by itself washes away the minerals in the soil it making sugarcane less productive and more susceptible to disease. In addition, furrow irrigation creates unwanted water in the field that damaging the roots and reducing productivity. To improve this uses result of technology that can increase the productivity of sugarcane by ensuring proper flow of water. Sugarcane production can be improved by using a sprinkler and drip irrigation technology to improve the effects of flood irrigation. In [47] the drip irrigation adoption in sugarcane increases water use efficiency (60-200%), saves water (20-60%), reduces fertilization requirement (20-33%) through fertigation, produces better quality crop and increases yield (7-25%) as compared with conventional irrigation. However, if not installed properly, it may result in wastage of water, time, money and yield.

This study differs from the others technology in the above solution. Thus, solution have been applied to increase sugarcane production, but to implement them is high cost for infrastructure like satellite cost, labor cost and wastages of water. so, the proposed solution to applied by simple cost, without human intervention and ones install for a long time. The problem is that it is difficult to obtain accurate data on the productivity of sugarcane by comparing the data on the productivity of sugarcane. To solve the problem the study is designed to provide accurate information from the sugarcane filed area and to give make a batter decision. GPS Technology is unusable and difficult to use. The proposed IoT technology to implement it's simple to use. The technologies mentioned above are difficult to manage the real data and reliability is greatly diminished, but in this study, they are reliable because they can provide information on sugarcane productivity. This study is safe for anyone to log in and access information anywhere only if they have a User Name and Password. But the above solution is difficult to find information from anywhere. Climate-related factors that reduce sugarcane productivity and increase productivity have been included in this study, such as temperature and humidity, which are different from other studies. Finally, the implementation of this technology will reduce the labor cost and improve sugarcane

production. So, from this proposed solution introducing a new Agricultural sugarcane technology for our country.

### 4.3 Proposed System Architecture

In this research, tried to address one of the challenges faced in sugarcane production. Sugarcane in Wonji/Shoa sugar factory is given the needed attention in terms of improve sugarcane Production such us, temperature, humidity and soil moisture level. As a result, the existing area on the sites makes it difficult to manage and monitor using existing approach. Thus, there was a need to design a system for monitoring sugarcane Productivity using the state-of-the-art technology. An automated system for improve sugarcane production conditions done with appropriate taxonomies. This research proposed IoT based improving sugarcane Production prototype in order to manage and control sugarcane plantation. It's focusses on collecting information from the field like environmental factors temperature and humidity in addition to the water level of the soil plays a major role for the growth of cane plant. The proposed prototype environmental conditions of cane plant are collected by using different sensor and real-time data transmitted to the Internet by the wireless sensor network. In addition, the internet gateway unit handles the sensor information, and transmits the data to web applications for further visualization. In the following section will discuss the proposed system architecture.

#### 4.3.1 System Architecture

The proposed architecture of the improving sugarcane production of IoT in plantation area and process flow are showing and discussed in figure 4.1.

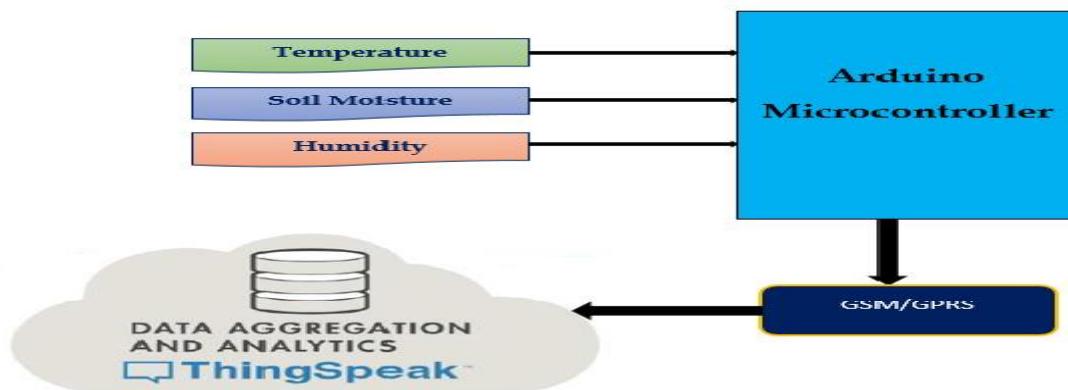

Figure 4.1: Proposed System Architecture for sugarcane plant monitoring

The proposed system mainly focuses on collecting the information from the sugarcane field area. Environmental factors like temperature, humidity and the soil moisture level play a major role for the growth level of a sugarcane plant. The different types of sensors are used for collecting the data like soil moisture sensor, humidity sensor and temperature sensor.



Figure 4.2: Different types of Sensors uses in gather information from field

The types of sensors that are shown in the figure 4.2 were used in this research; in which the temperature and humidity sensor will give the details information about temperature and humidity values of the environment and moisture sensors measures the water content in the soil. Those devices are used for the measurement and connect with the microcontroller Arduino.

Arduino is an open-source tool for developing computers that can sense and control more of the physical world than desktop computer. It is an open-source physical computing platform based on a simple microcontroller board, and a development environment for writing software for the board. The Arduino microcontroller is the heart of this architecture. It constantly performs the analogue to digital conversion of the various sensors, verifies them and checks if there is need for any corrective action is to be taken at that instant of time. A GSM/GPRS module it is included in this Architecture to enable you to send this to the Internet by reading the correct data from the board. ThingSpeak IoT provides excellent tools for IoT-based projects. Using the ThingSpeak IoT platform, you can make a decision that you can track your information from anywhere on the Internet, and you can also control your system over the Internet using the channels and websites provided by ThingSpeak. ThingSpeak ‘collects’ data from the sensors, analyzes and visualizes data and acts by triggering feedback. The proposed architecture had four sections, firstly soil, humidity and temperature sensor DHT11 senses the humidity and temperature data, and Grove sensor senses soil moisture

level. Secondly Arduino extracts the DHT11 and Grove sensor's data as suitable number in percentage and Celsius scale, and sends it to GSM/GPRS module. Thirdly GSM/GPRS module uploads the data to ThingSpeak's sever. And finally, ThingSpeak analyses the data and shows it in a graph form. In this research we are planned to monitor the current status of the soil, humidity and temperature over the Internet using ThingSpeak IoT platform for monitoring real time data from anywhere in the world and can be used for decision making using the internet.

## **4.4 Requirement Specification**

In this section different hardware, software and platform required for deploying the proposed system were discussed.

### **4.4.1 Software Requirement**

#### **4.4.1.1 Arduino IDE Software**

The Arduino integrated development environment (IDE) is a cross-platform application written in Java, and is derived from the IDE for the Processing Programming Language and the wiring projects. It is designed to introduce programming to artists and other newcomers unfamiliar with software development. It includes a code editor with features such as syntax highlighting, brace matching, and automatic indentation, and is also capable of compiling and uploading programs to the board with a single click. A program or code written for Arduino is called a "sketch" [48].

Arduino is an open-source platform comprising of both a physical Programmable Circuit Board (often referred to as a microcontroller) and a piece of software that can be installed on the computer, used to write and upload computer code to the physical board. The Arduino software works on all known operating systems. It is an Integrated Development Environment (IDE) that provides programmers with tools such as a source code editor, automation tools, and a debugger [49].

## 4.4.2 Hardware Requirement

### 4.4.2.1 The Arduino UNO

From the Specification of Arduino Uno microcontroller board are 14 digital pins the right and left side of a boards for input/output, 6 analog inputs, a 16 MHz crystal oscillator, a USB link, a power jack, an ICSP header, and a reset button (of which 6 can be used as PWM outputs). It includes anything required to help the microcontroller; simply connect it to or power it with an ACC device with a USB cable. The Uno differs from all previous board's types in that the USB-to-serial driver chip is not included. It features the Atmega8U2 programmed as a USB-to-serial converter instead. The reference versions of Arduino, going forward, will be Uno and version 1.0. The Uno is the newest Arduino USB board in a series of USB Arduino boards, and the Arduino platform reference model [50].

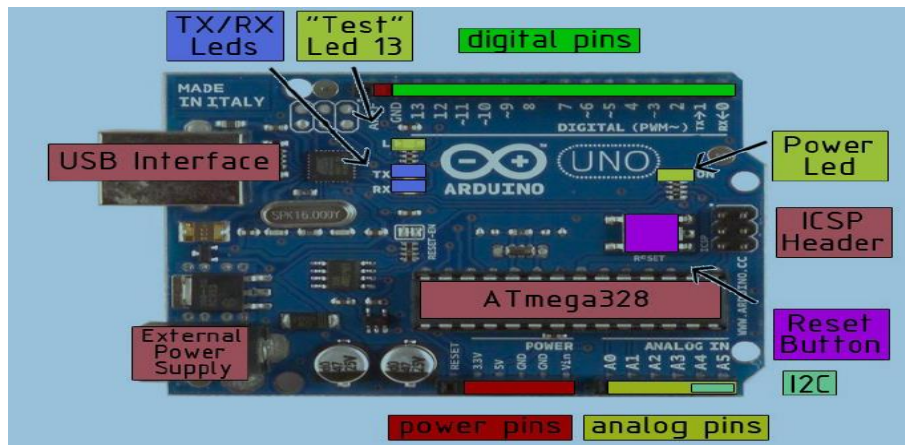

Figure 4.3: The Arduino UNO

The technical specification of the Arduino Uno can be powered via the USB connection or with an external power supply. The power source is selected automatically. External (non-USB) power can come either from an AC-to-DC adapter (wall-wart) or battery. The adapter can be connected by plugging a 2.1mm center-positive plug into the board's power jack. Leads from a battery can be inserted in the Gnd and Vin pin headers of the POWER connector. The board can operate on an external supply of 6 to 20 volts. If supplied with less than 7V, however, the 5V pin may supply less than five volts and the board may be unstable. If using more than 12V, the voltage regulator may overheat and damage the board. The recommended range is 7 to 12 volts [50].

The power pins are as follows:

- VIN. The input voltage to the Arduino board when it's using an external power source (as opposed to 5 volts from the USB connection or other regulated power source). You can supply voltage through this pin, or, if supplying voltage via the power jack, access it through this pin.
- 5V. The regulated power supply used to power the microcontroller and other components on the board. This can come either from VIN via an on-board regulator, or be supplied by USB or another regulated 5V supply.
- 3V3. A 3.3-volt supply generated by the on-board regulator. Maximum current draw is 50 mA.
- GND. Ground pins.

The Arduino platform has become very popular with amateurs and professionals alike. Amongst other reasons, the Arduino does not need a separate programmer in order to upload program codes onto the board. It comes pre-burned with a bootloader that allows you to upload new code to it without the use of an external hardware programmer. A USB cable is used to connect the Arduino hardware to the computer and the instruction codes are uploaded from the Arduino software [49].

#### **4.4.2.2. Grove Soil Moisture sensor**

The soil moisture sensor is used to sense moisture content in the soil. It checks the volume of water content or moisture present in the soil. The calculations are done in the soil moisture sensor through coefficients. It estimates the volume of water content in the soil. It detects the water content in the soil and gets and sends the analog signals which is shown digitally. It transmits the signals containing information or data or values of the condition of soil to Arduino to further process it and display [51].

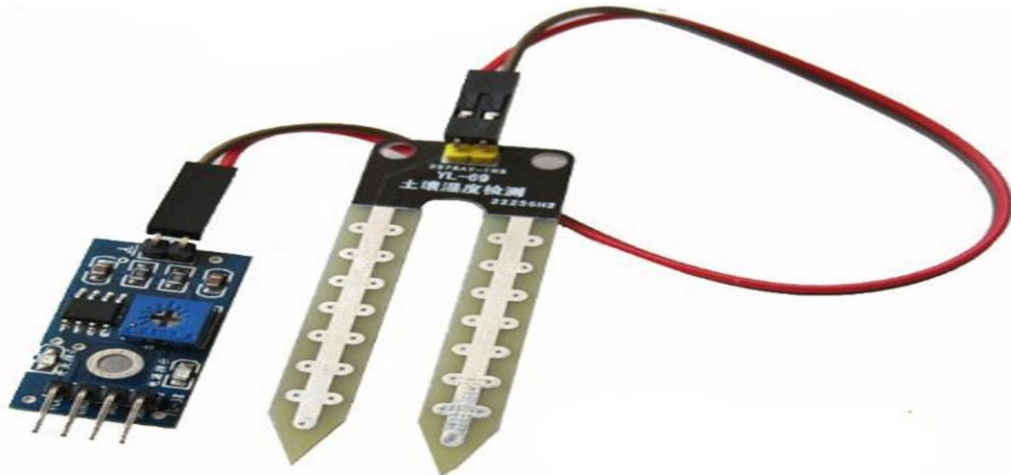

Figure 4.4: Soil moisture sensor

The soil moisture sensor consists of two probes which are used to measure the volumetric content of water. The two probes allow the current to pass through the soil and then it gets the resistance value to measure the moisture value. When there is more water, the soil will conduct more electricity which means that there will be less resistance. Therefore, the moisture level will be higher. Dry soil conducts electricity poorly, so when there will be less water, then the soil will conduct less electricity which means that there will be more resistance. Therefore, the moisture level will be lower.

#### 4.4.2.3 DHT11 Humidity Temperature Sensor

The DHT11 is a basic, low-cost digital temperature, and humidity sensor. It uses a capacitive humidity sensor and a thermistor to measure the temperature. The only real downside of this sensor is that it can only get new data from it once every 2 seconds. It has a measurement range of 0-50°C and has temperature accuracy of 2% and humidity accuracy of 5%. It takes a maximum of 2.5mA current while measuring the temperature and in an average, takes a current of 1mA [52].

It uses serial mode of communication to communicate with the microcontroller. All the sensor readings are sent using a single wire bus which reduces the cost and extends the distance. The humidity sensing component is a moisture absorbing substance with two electrodes applied to the surface. The sensor measures the electrical resistance between two electrodes and the IC mounted on the back of the module converts the measured resistance to relative humidity. The relative humidity is inversely proportional to the resistance between the electrodes [52].

The single wire serial interface allows integration of the device fast and simple. Its small size, low power consumption and signal transmission of up to 20 meters make it the best option for different applications, including the most demanding ones. The component is 4-pin single row pin package and in following figure 4.5, shows interfacing DHT11 with Arduino.

DHT11 pin out:

- ✓ The first pin of the DHT11 is VCC pin.
- ✓ The second pin of the DHT is Data pin.
- ✓ The third pin is not used.
- ✓ The fourth pin of the DHT sensor is ground.

The DHT11 Temperature and Humidity sensor is used to sense temperature and humidity present in the atmosphere. It has 3 pins generally. One pin is used for transmitting signals, the next pin is used to receive signals and the last pin is data transfer. It can be used for prolonged time period. It gives approximate results. It regularly sends information to Arduino UNO. The information consists the signals which contain the values gathered about temperature and humidity. It is reliable on nature. It gives a very fast response [51].

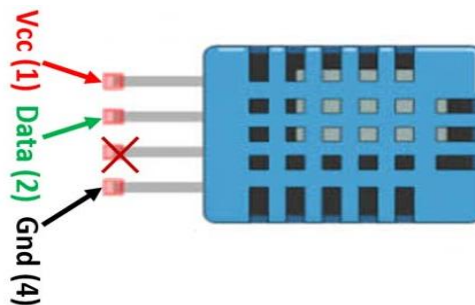

Figure 4.5: DHT11 sensor

#### 4.4.2.4 A6 GSM/GPRS module

A GSM/GPRS Module is a chip that is actually in charge of GSM Network wireless communication. A GSM/GPRS MODEM is a system that modulates and demodulates wireless network signals and makes it possible to connect to the internet. A GSM modem or GSM module is a hardware device which provides a data link to a remote network using GSM mobile telephone technology. They are practically similar, from the point of view of the cell phone network, to the ordinary mobile phone, including the need for a SIM to distinguish the network itself.





Figure 4.6: A6 GSM/GPRS module

The module needs an external antenna for any kind of voice or data communications as well as some SIM commands. So, it usually comes with a small duck antenna having 2 dBi gain and 50Ω impedance which provides great coverage even if your project is indoors. There is a Power button provided to turn the module ON/OFF manually, though you can do this programmatically. The status of the module is indicated by an LED on the top right side of the Module. Though the module can work on 5V, the operating voltage of the chip is from 3.3V to 4.2V. To keep supply voltage safe at 4.1V, the module comes with a high frequency step-down switching regulator MP1584 from Monolithic Power Systems – capable of handling load currents up to 3A. The module can also be powered through a micro-USB connector. You can just grab your cell phone’s wall charger (rated 5V 2A) and power up the module. There’s a SIM socket on the back! Any activated, 2G micro-SIM card would work perfectly. The workings of the SIM card socket can take some getting used to. To unlock the latch, push the top part of the assembly towards micro-USB connector, and then lift it up. Place the SIM card into the bottom part of the socket with the SIM’s notch pointing away from the micro-USB connector. Then fold the arm back into the body of the socket, and gently push it forward towards the “LOCK” position [53].

### 4.4.3 Platform Requirement

#### 4.4.3.1 ThingSpeak Platform

ThingSpeak is a web based open API IoT platform that comprehensive in storing the sensor data of varied ‘IoT applications’ and conspire the sensed data output in graphical form at the web level. ThingSpeak communicate with the help of internet connection which acts as a

'data packet 'carrier between the connected 'things' and the ThingSpeak cloud retrieve, save/store, analyze, observe and work on the sensed data from the connected sensor to the host microcontroller such as 'Arduino, TI CC3200 module, Raspberry-pi etc. [5]. The most primary feature of ThingSpeak functionality is the term 'Channel' that have field for data, field for location, field for status for varied sensed data. Once channels are created in the 'ThingSpeak' the data can be implemented and alternately one can process and visualize the information using the MATLAB and respond to the data with tweets and other forms of alerts. ThingSpeak also provide a feature to create a public based channel to analyze and estimate it through public. To Engage the 'Things/objects' in sensing the respective data and transmitting across the Internet and one involves to go further just connecting data from a PC, objects (sensors)to collect the data require to network uploaded that are in the form of servers (that runs applications) that considered as Cloud. The 'Cloud' utilizes the operations of Graphical visualization and available in the form of Virtual server for the users and the objects are communicated with the cloud via possible 'wireless internet connections' available to the users and majority objects uses the sensors/actuator to tell regarding our environmental analogue data. The IoT Helps to bring all things together and permits us to communicate with our very own things and even more curiously allows objects/things to interact with other 'things' [5].

## **4.5 System Design**

### **4.5.1 Design Goal**

The proposed system was expected to solve the problems of the existing system in the production of sugarcane, in the case of Wonji/Shoa sugar factory improving sugarcane Production. This will help meet the demand for sugar in our country and create a competitive industry by develop new systems.

#### **4.5.1.1 Interface**

The interface of the system should be clear and user friendly, that is, it should be easily, understandable, usable and corrective.

#### **4.5.1.2 Security Issue**

Secure information transmission was a critical issue to ensure system reliability of the IoT prototype. Anyone to accessing the system must be secure. Only authorized users must register and create your account and use secure system functions in accordance with established standards.

#### **4.5.1.3 Performance**

The performance of the system should be reliable and the response time of the system should be short. In this research used different sensor DHT11 and Grove sensor for monitoring soil moisture level, humidity and temperature. The sensors are very popular for electronics because there are very cheap but still providing great performance. And also, DH11 sensor includes a resistive-type humidity and temperature measurement component, and offering excellent quality, fast response and cost effectiveness.

#### **4.5.1.4 Reliability**

The proposed system will minimize crash during its runtime, since more than one user could use the ThingSpeak API simultaneously. DHT11 Temperature & Humidity Sensor features a temperature & humidity sensor complex with a calibrated digital signal output. By using the exclusive digital-signal-acquisition technique and temperature & humidity sensing technology, it ensures high reliability and excellent long-term stability.

#### **4.5.1.5 Maintainability**

The proposed system should be developed for easy future maintenance and enhancement if there are additional sensor, maintain system failure and shifts by emerges new technological.

#### **4.5.2 Sub -System Decomposition**

The system has three main functionalities which are data recording, converting and notifications. Data recording functionality is where the sensors carry out data abstraction in real time. The sensors record temperature, humidity and soil moisture.

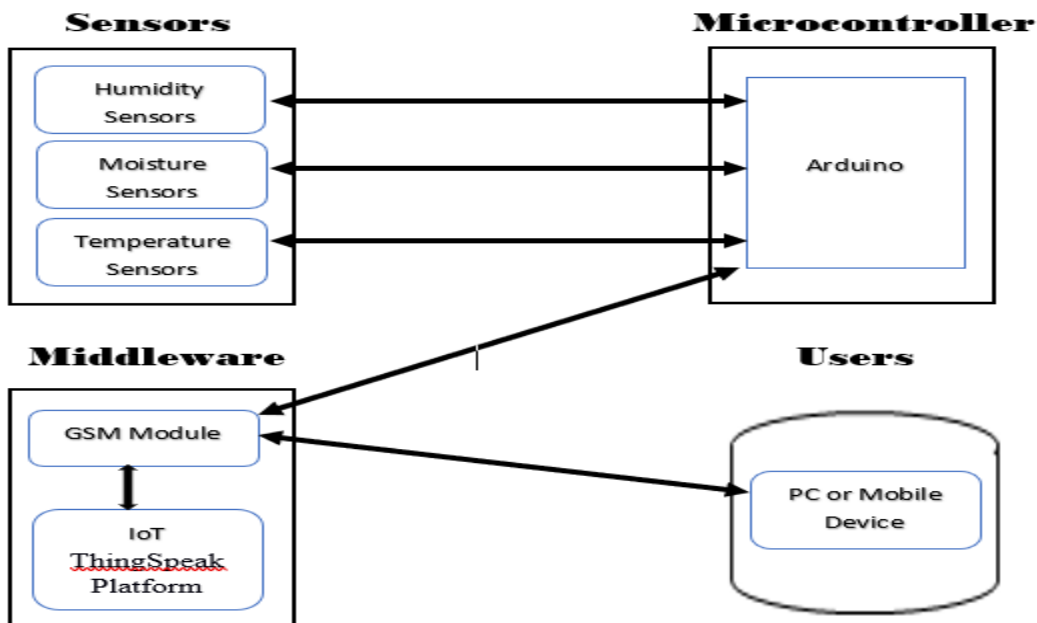

Figure 4.7: Sub- system Architecture

This functionality is achieved by the Arduino board with the assembled sensors. Event-processing service functionality involves having IoT ThingSpeak platform where the user can view the trends of the environmental condition and so on.

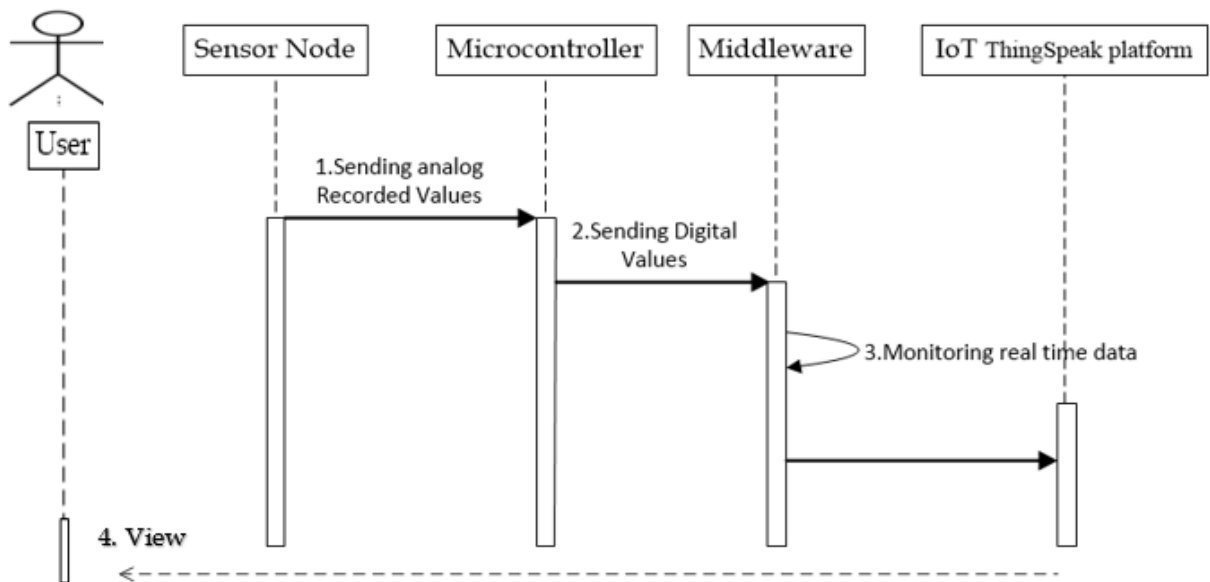

Figure 4.8: Sequence Diagram for the proposed system

The Sequence Diagram represents the process of data being sending analog values by the sensors, converted to digital values which are then sent to the middleware for visualize and analysis. According to the need the analyzed information is also stored in the server for recorded the previous (historical) data analysis and for further visualization in graph. Figure 4.9 more clarifying and discussed the proses flow of the proposed system.

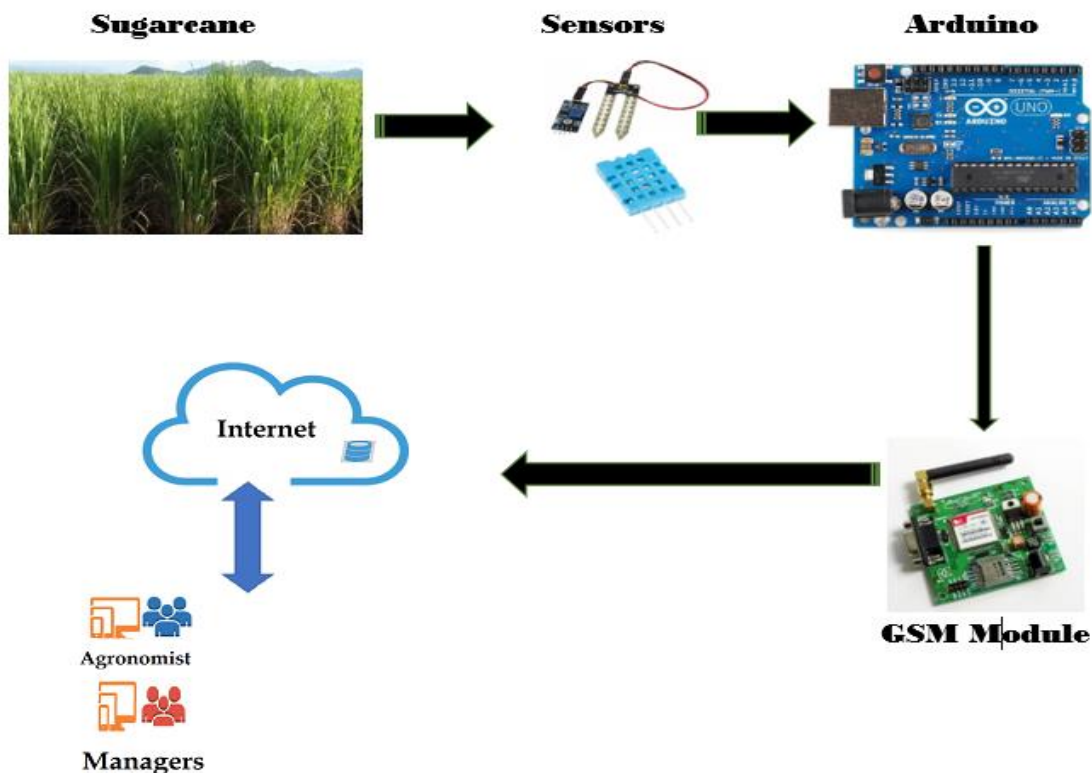

Figure 4.9: Process flow

The process flow figures the initial data is collected from the sugarcane area in the filed by the sensors. Different types of sensors are installed in the area for collecting different set of data. The information collected from the sensors will be passed to Arduino and the information obtained can be easily accessed by viewing the data. the information is sent to the participants through the GSM/GPRS module. The participants can get the details about the current condition of the sugarcane area from any filed, such as; Humidity, Temperature, Soil moisture level using Internet. The other mechanism will be depending upon the result of the process what are the actions can be taken. The humidity sensor will send the data related to the water level and depend upon the outcome whether the level is low or high

corresponding action will be taken by the participants (Agronomist). The programming part can be done by using the Arduino IDE, different set of actions are initiated depends upon the functionality that is given in the program. The moisture level will be increased or decreased depends upon the time. The moisture level will be monitored and the corresponding action will be taken. This process will maintain the moisture level of the soil and it will in turn make an increase in the growth of the Sugarcane. The temperature will be increasing depend on the time from Morning to evening. By using open API IoT source information platform ThingSpeak that comprehensive to storing the sensor data of varied IoT applications. ThingSpeak cloud is the data to retrieve, save/store, analyze, observe sensed data from the connected sensor to Arduino. Finally, the end users to uses for a decision making from this collected data can be analyzed, store and visualized using in the form of graphs and charts to give a better understanding of environmental conditions and soil conditions to the participants.

## **CHAPTER FIVE**

### **IMPLEMENTATION AND TESTING**

#### **5.1 Overview**

This chapter presents implementation of the proposed prototype and testing of the proposed solution. The detail description of these components is presented in various sections and this chapter describe how to interface different hardware and software to design and develop the prototype. Finally, discussed the system test were summarized.

#### **5.2 Implementation**

In this section, discussed the implementation of the prototype using different sensors, Arduino microcontroller, and GSM/GPRS module to communicate with ThingSpeak platform and the results are displayed in figures.

##### **5.2.1 Development tools**

In this study document is the place where the hardware and the software for its installation and calibrating to prepared for develop the Prototype. To do this, try to put it below.

###### **5.2.1.1 Installation Arduino IDE and its Library**

First to get the latest version from the link <https://www.arduino.cc/en/guide/windows#toc1> then go to the download page and download windows version. You can choose between the Installer (.exe) and the Zip packages. We suggest you use the first one that installs directly everything you need to use the Arduino Software (IDE), including the drivers. With the Zip package you need to install the drivers manually. The Zip file is also useful if you want to create a portable installation. When the download finishes, proceed with the installation and please allow the driver installation process when you get a warning from the operating system and Follow the necessary steps. Finally find the Arduino shortcut on your Desktop and click on it. The IDE will open up and you'll see the code editor and install or update the necessary the library files in the Library Manager.

### 5.2.1.2 Circuit diagram for Soil Moisture Sensor and Arduino

To connect the sensor in the analog mode, we will need to use the analog output of the sensor. When taking the analog output from the soil moisture sensor FC-28, the sensor gives us the value from 0-1023. The moisture is measured in percentage, so we will map these values from 0 -100 and then we will show these values on the serial monitor. Diagram The connections for connecting the soil moisture sensor FC-28 to the Arduino are as follows [54].

- VCC of FC-28 to 5V of Arduino
- GND of FC-28 to GND of Arduino
- A0 of FC-28 to A0 of Arduino

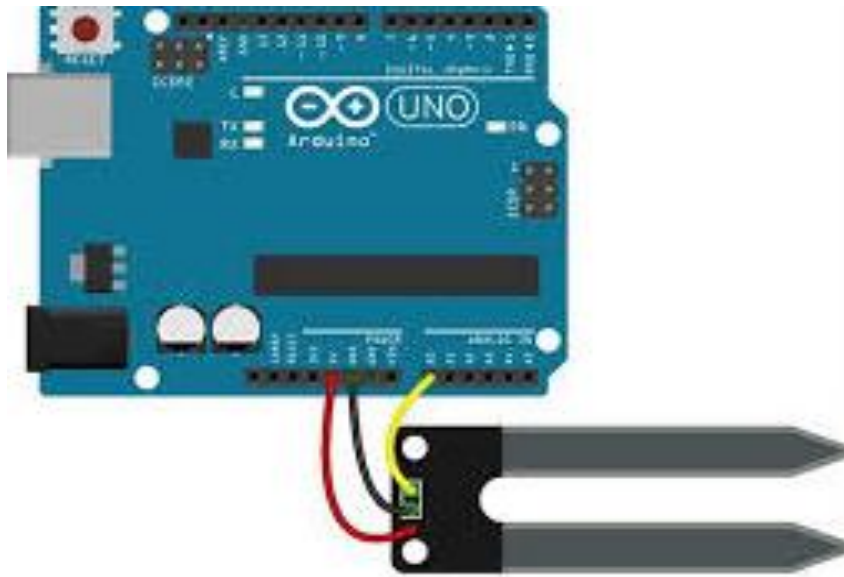

Figure 5.1: Moisture sensor with Arduino Connection

### 5.2.1.3 Circuit diagram for DHT11 Sensor and Arduino

The DHT11 is a commonly used Temperature and humidity sensor. The sensor comes with a dedicated NTC to measure temperature and an 8-bit microcontroller to output the values of temperature and humidity as serial data. The sensor is also factory calibrated and hence easy to interface with other microcontrollers. The sensor can measure temperature from 0°C to



50°C and humidity from 20% to 90% with an accuracy of  $\pm 1^\circ\text{C}$  and  $\pm 1\%$ . So, if you are looking to measure in this range then this sensor might be the right choice [55].

#### Pin Identification and Configuration:

- Vcc Power supply 3.5V to 5.5V
- Data Outputs both Temperature and Humidity through serial Data
- NC No Connection and hence not used
- Ground Connected to the ground of the circuit

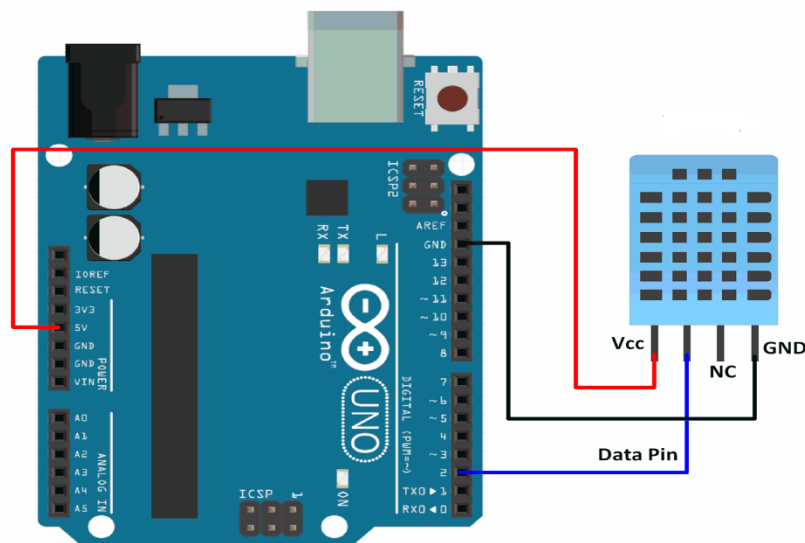

Figure 5.2: DHT11 sensor with Arduino Connection

**Note:** - After the hardware is wired, there is Add an Arduino installation library (DTH library), and the following steps are illustrated to install Arduino IDE.

Step1: Download the library of DHT from the link:

<https://drive.google.com/file/d/0B1paTI5fzcHodno5azFOSVVDT0E/view?usp=sharing>

Step2: -Go to Sketch--> Include Library --> browse and Add Zip File

Step3: - If you close and reopen the Arduino software the new library will be included.

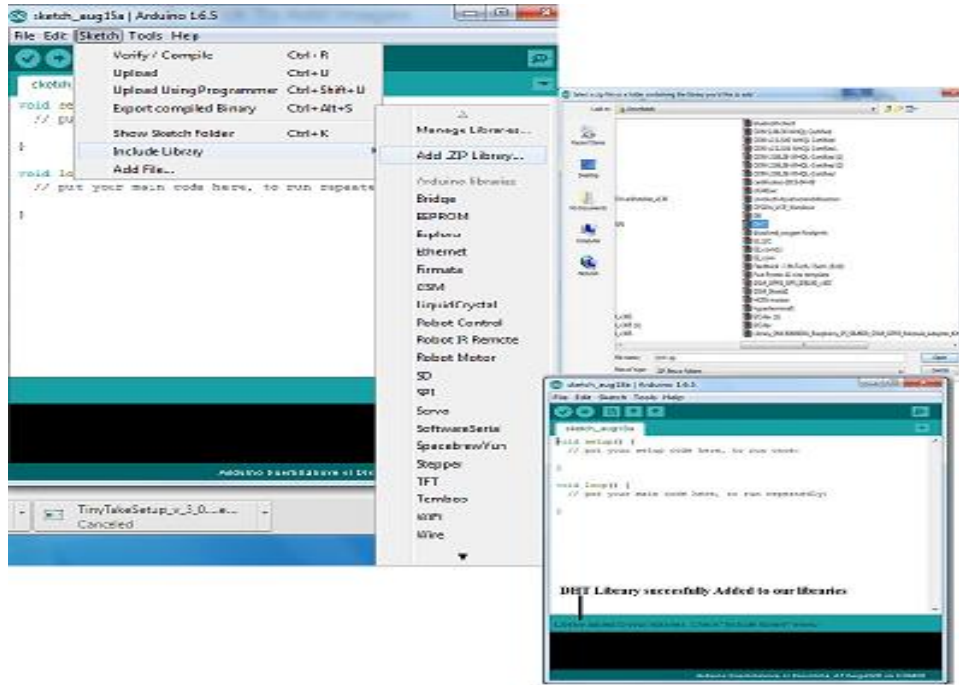

Figure 5.3: Include DHT Library

### 5.2.1.1 Interfacing A6 GSM module to Arduino

The A6 GSM/GPRS module is a miniature GSM modem that can be used in a wide variety of IoT projects. You can use this module to do almost everything a standard mobile phone can, including sending and receiving SMS text messages, making and receiving phone calls, connecting to the internet through GPRS, TCP/IP, and more! To top it off, the module operates with a quad-band GSM/GPRS network, which ensures it can be used virtually everywhere in the world. To start, connect the module's U Tx/D and U Rx/D pins to digital pins #3 and #2 on the Arduino, as we'll be using software serial to communicate with the module. Attach the module's VCC pin to the 5V 2A rated external power supply. Do not be tempted to attach this pin to the Arduino 5V supply, as due to the lack of supply current, the module will not work. Link all the ground in your circuit now.

Wire	A6 Module	Arduino Uno
BLACK	GND	GND
RED	VCC	VCC
YELLOW	U_TXD	PIN_3

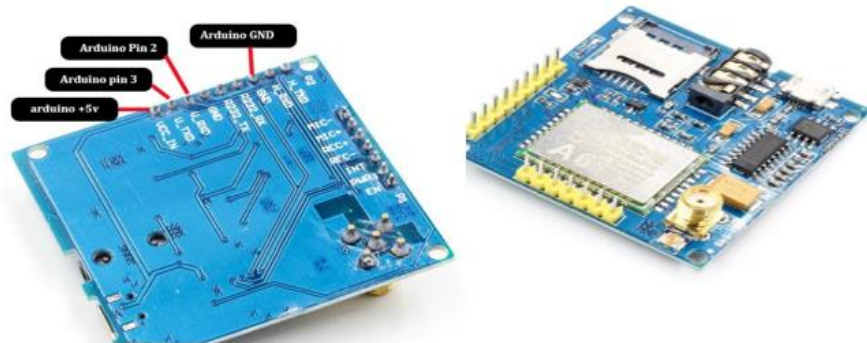

Figure 5.4: A6 GSM Module Arduino Connection

## 5.2.2 Prototype

Follow the steps below to install this prototype used on the Windows operating system on a laptop or desktop.

Steps 1: Installing Arduino IDE and its Library for windows Version.

Steps 2: Collecting the calibrated sensors and GSM/GPRS module with the Arduino expansion board.

Steps 3: Ready for Implementing of the prototype around Sugarcane Plant.



Figure 5.5: Implementing of the prototype Sugarcane Plant

Steps 4: Using an Arduino UNO and a GSM/GPRS package, data from soil moisture, temperature, and humidity sensors is submitted to a ThingSpeak channel.

Steps 5: You can easily sign in either using your ThingSpeak account or Mathworks account, or create a new Mathworks account via following link: [https://Thingspeak.com/users/sign\\_up](https://Thingspeak.com/users/sign_up)

Steps 5.1 After Visiting the ThingSpeak URL click on “Sign up”

Steps 5.2 Fill the following mandatory fields: User ID, E-mail, Time Zone, Password and Password Confirmation and then Click "Create Account" on the bottom of the windows.

Steps 5.3 The new channels to create “Create New Channel" from the drop-down menu.

Fill the Channel Name, Description, Field Name in Field 1 is 'Humidity', Field 2 is 'Temperature' and filled 3 is 'Soil moisture' and tick the box to allow the field

Finally, press Save Channels to creating a channel.

Figure 5.6: Creating New Channels

Steps 6. Click New Channel to create a new ThingSpeak channel. Click on the column headers of the table to sort by the entries in that column or click on a tag to show channels with that tag. Learn to create channels, explore and transform data. Finally, the Click "Update Channel"

Figure 5.7: Created Channels on the ThingSpeak

Steps 7: - To get the API key needed by the installer and save the Write and Read API keys, press the 'API Key' tab, here we just use Write Key. In the file, you need to copy this key into char \*api key. Clicking on Humidity and Temperature Channels, for example, will show you how to create an API key Figure 5.8.

Figure 5.8: Generating New API Key

Steps 8: The raw data gathered from different sensors are converted using Arduino board and displayed using Arduino software. Before reading the sensors, data installing (Configuring) USB2-Serial Port. The numerical values display in the Arduino IDE and the current data will be stores in ThingSpeak channels before displays the graphical representation.

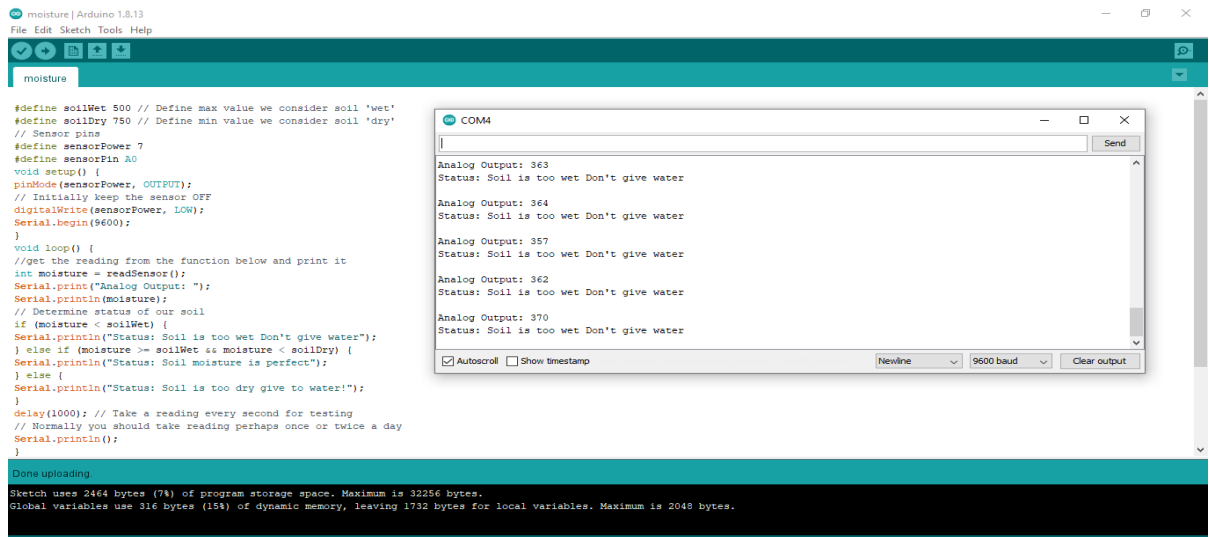

Figure 5.9: Read and Output of Soil moisture values

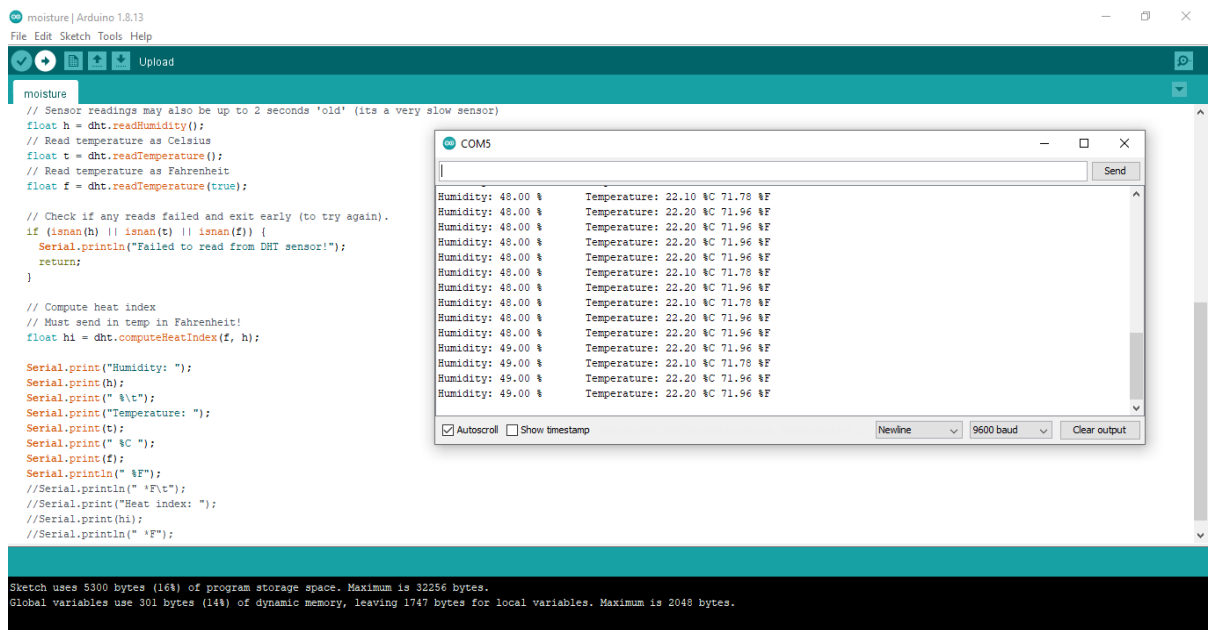

Figure 5.10: Read and Output of Temperature and Humidity values

In the following figure 5.11 the ThingSpeak result shown and according to its need we can analyze and visualize in graphical form. Before the result is displayed add the ThingSpeak Library files in the Arduino IDE.



Figure 5.11: Output of soil moisture ThingSpeak Result

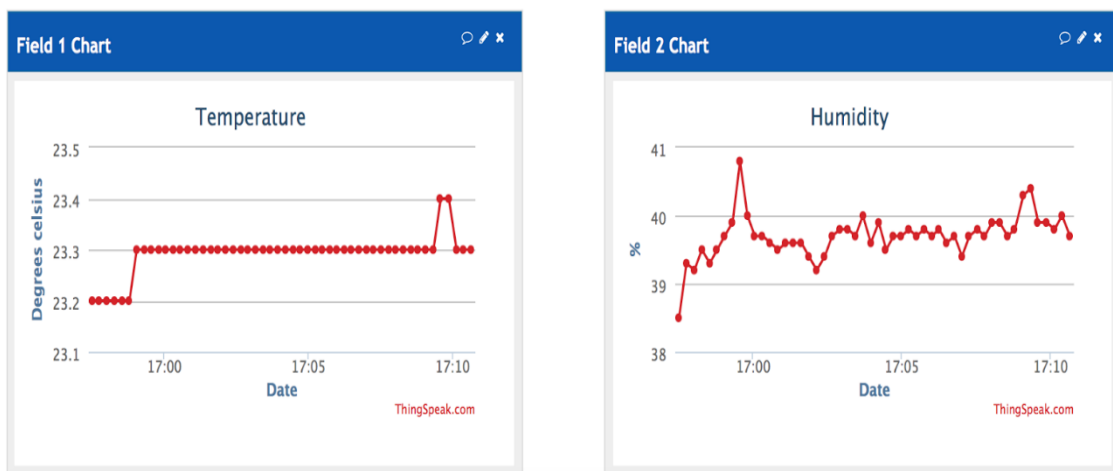

Figure 5.12: Output of Humidity and Temperature ThingSpeak Result

### 5.2.3 Testing

The testing of new product, we conducted usability testing. This testing was carried out to evaluate the overall performance of the proposed system. The goal of the usability test conducted to assess the system's learnability for first-time users of the system, to evaluate the efficiency and performance of the system. The target users are of the systems are Agronomist, irrigation expert and Plantation managers. To evaluate the system twelve Agronomist, two irrigation engineers. seven Agriculture officers and two managers from different plantation departments were participated. The testing session takes approximately about 20-35 minutes and held at evaluator premise. We prepared questionnaire to each evaluator of the system to conduct the usability testing. The question was designed to gather quantitative results from target users. The questions in include criteria such as functionality, usability, usefulness, and effectiveness. The designed questions are easy and understandable to make the evaluation process easy. There are 12 question and the taster has only one option to select for each question.

After the tasters conducted the usability testing on the developed system, questioners were distributed to each participant. The scale of the questioners was based on a scale of 1 to 5, where (strongly agree=5, agree =4, neutral=3, disagree=2, strongly disagree=1). The evaluation result is presented in table 3.

Table 5.1: Evaluation Question

Evaluation Questions		Values				
		1	2	3	4	5
1	The System is easy to learn?		2		7	8
2	The System is easy to use?	1	1		8	6
3	The IoT platform well organized and functions are easy to find?	2	2	1	6	6
4	The user Interface of the system is pleasant?	2	2		7	6
5	Are you confident to use the system?	1	1	2	6	6



Evaluation Questions		Values				
		1	2	3	4	5
6	The system response is quick?				8	8
7	The system is helpful to use?				9	9
8	Do you think people would learn to use this system very quickly?	1	2	2	6	5
9	Do you think that you wouldn't need the support of a technical person to be able to use this system?	1	2		7	8
10	Do you find the various functions in this system were well integrated?			4	8	6
11	How successful is our software in performing its intended task?			2	9	6
12	What is your overall satisfaction of the system?	1	1	1	10	9

After gathering all responses from the questioners provided to the tasters, we found that Percentage of Strongly Agree and Agree response= $40.86\%+42.78\% = 83.65\%$ .

Among the respondents  $\approx 83.65\%$  of the participant have responded with either strongly agree or agree reply for the usability test questions. From the evaluation analysis, we can conclude that the developed system met its objective. The evaluation summary result is presented in table 4.

Table 5.2: Evaluation Result

Q. No	Response	Values					Total respondent
		Strongly agree	Agree	Neutral	Disagree	Strongly Disagree	
1	Frequency	7	8		2		17
	Percent	41%	47%		12%		100%
2	Frequency	6	8		1	1	16
	Percent	38%	50%		6%	6%	100%
3	Frequency	6	6	1	2	2	17
	Percent	35%	35%	6%	12%	12%	100%
4	Frequency	6	7		2	2	17
	Percent	35%	41%		12%	12%	100%
5	Frequency	6	6	2	1	1	16
	Percent	38%	38%	13%	6%	6%	100%
6	Frequency	8	8				16
	Percent	50%	50%				100%
7	Frequency	9	9				18
	Percent	50%	50%				100%
8	Frequency	5	6	2	2	1	16
	Percent	31%	38%	13%	13%	6%	100%
9	Frequency	8	7		2	1	18
	Percent	44%	39%		11%	6%	100%
10	Frequency	6	8	4			18
	Percent	33%	44%	22%			100%
11	Frequency	9	6	2			17
	Percent	53%	35%	12%			100%
12	Frequency	9	10	1	1	1	22
	Percent	41%	45%	5%	5%	5%	100%
		<b>40.86%</b>	<b>42.78%</b>	<b>5.76%</b>	<b>6.25%</b>	<b>4.32%</b>	<b>100.00%</b>
		<b>83.64%</b>					

The data collection methods and testing questions to be investigated and discussed its usability. In testing and evaluating feedback sugarcane experts understand how the features of the proposed system improve sugarcane plant. And also, how the proposed system addressed the challenges faced in sugarcane plantation and growth.

#### 5.2.4 Result and Discussion

In this study seeks to identify the factors affecting of sugarcane productivity and to identify the challenges encountered to create solutions to the problems by design and develop a prototype that will address the needs of the factory problem. and test whether the prototype meets desired functions.

The respondents of the research employees at WSSF Plantation office and Research center were asked several questions regarding to show the level of satisfaction with the system usability and better understand of user. Responses were measured on five-point Likert scales. These results demonstrate that most respondents strongly agree and agree (83.64%) indicated that they are comfortable to use the system and that they felt welcome. However, a small number of employees were neutral (5.76%) and to disagreed and strongly disagree respectively (6.25%, 4.32%) to use this artifact. The selected employees are directly involved in the work and some of the employees are not directly involves the works.

According to the study, there are many problems with the development of sugarcane production, but it is possible to increase sugarcane productivity by using this kind of technologies that help to solve this problem and by organizing, Analyzing and storing filed data. According to the sugar factory's plan, there is no alternative to supporting this type of technology to meet the demand of our country and build an internationally competitive sugar industry. To do this the Ethiopian Sugar Corporation research department needs to facilitate and dissemination in collaboration with the factory's Plantation department.

Each IoT agricultural application focuses primarily on their domains (monitoring, controlling, and tracking). Irrigation Management and Controlling, Temperature Monitoring, Humidity Monitoring, and Water Monitoring and Controlling are the major types of these applications.

This Internet of Things prototype had the following strengths which make it a stronger architecture to be deployed in sugarcane Production. The prototype allows for interoperability where different sensors devices and technologies to inter- connect creating an embedded system. The inter-connected systems are GSM/GPRS, Arduino UNO, Grove Sensors, DHT11 Sensors and ThingSpeak Cloud IoT platform. Thus, are collected data from

the field can be analyzed, store and visualized using graphs and charts to give a better understanding of the current conditions of the field and giving a better decision for Sugarcane Plant. The Prototype has been able to achieve this by using the Internet-based ThingSpeak API, which allows the agronomist and Plantation manager to remotely monitor the sugarcane plant to visualize intelligent results.

The results show that IoT technology has been shown to have a positive impact on sugarcane production and improved product quality by reducing unnecessary irrigation costs. In WSSF irrigation uses flood irrigation system around 98,133,788.14 m<sup>2</sup> Volume of water uses annually in different states of the field (Estate, Dodota and Waketio) and the irrigation costs of each month 188,556.5 birr/month per hectares. This study shows that the technology contributes to the improv sugarcane production with minimizing the costs of production and reducing wastages of waters.

In addition, IoT technology is solving many problems in agriculture. The limitation of materials and internet infrastructure problem we need to consider in our country. Further in-depth research and other work needs to be done, and if there is not much research in this area in our country, so more research will be done in this area.

## CHAPTER SIX

### CONCLUSIONS AND FUTURE WORKS

#### 6.1 Conclusions

The development of modern agriculture is an effective way to solve the problem of production of sugarcane. The use of Internet of Things technology in agriculture is a symbol of the process of improving technical problems in sugarcane production. In recent years, the application and improvement of technologies in the Internet of things on agriculture, including wireless sensor networks, automation control system and so on. The main challenges of improve sugarcane production in Wonji sugar factories are lack of giving a proper water to a cane plants at right time that is the irrigation problems. The determine the soil moisture suitability for a plant and checking the environmental conditions by using different sensors. By looking directly, the sensors seances data from the field and measure soil moisture and environmental condition and comparing with as per standard to determine when and how often to give a water for a plant. The sugarcane agriculture in Ethiopia still needs improved technologies that can alleviate the existing production challenges namely lack of high yielding modern cane varieties, prevalence of diseases and pests, reduced land productivity, rise of soil and water management, increased production costs, lack of training on appropriate technological advancements in sugarcane.

Ethiopia Naturally gifted land and water, so why improve sugarcane production in our country. To address this sector needs to be supported by technology. As a solution to this problem sustained efforts and holistic approach in integration of various sugarcane production technologies are required to be implemented to improve the productivity of cane and sugar. This paper presents on the IoT technology application in sugarcane agriculture, and selected sensors and ThingSpeak technology to achieve improve sugarcane production. The system allows to monitor the condition of soil moisture, humidity and temperature which all the sensor collected data in the field and send the data to the microcontroller though GSM/GPRS module to the ThingSpeak platform. This collected data were analyzed, store

and visualized using graphs and charts to give a better understanding of environmental conditions and moisture level of the soil to the field. Finally, improving the efficiency of sugarcane production can be supported by IoT Technology it is possible to achieve the desired result and increase the production of sugarcane.

## **6.2 Future Works**

Technological development and digitalization shape feasible boundaries to increase resource use efficiency. Smart sugarcane agriculture reduces the negative environmental impacts of farming, increases resilience and soil health, and decreases the production cost. The number and types of challenges associated with Improve IoT based sugarcane Production expand across various agricultural production systems, and infrastructural limitations apply when it comes to IoT implementation. Currently sugarcane production system at WSSF is Conventional methods, which have a significant impact on sugarcane production to low water availability and environmental monitoring. These, problem solves addressed using IoT technology to improve the efficiencies of sugarcane production. Therefore, as a future work to recommend doing research around sugarcane productivity in soil fertility, water supply, species selection and sugarcane technology. In addition, currently increasing Ground water is a major problem in sugarcane production at WSSF and if a sustainable solution can be done by studying further technological research will be done. With the help of sugarcane field historical data doing predicting crop cycle time by creating new system and look at the productivity of the field. so new changes can be made in improve sugarcane production as Agronomical problem and giving decision for real data.

## REFERENCES

- [1] D. Welteji, "A critical review of rural development policy of Ethiopia: access, utilization and coverage," *Agriculture & Food Security*, p. 2, 13 August 2018.
- [2] E. S. corporation, "https://etsugar.com," Ethiopian Sugar corporation, [Online]. Available: <https://etsugar.com>. [Accessed 18 February 2021].
- [3] N. J. Pavankumar, "Importance of IoT for Smart Agriculture," *IJSRD - International Journal for Scientific Research & Development*, vol. Vol. 4, no. Issue 12, pp. 379-380, 2017.
- [4] A. N. Partners, "Agtech companies," 9 July 2018. [Online]. Available: <https://agfundernews.com>. [Accessed Sep 2020].
- [5] S. Pasha, "Thingspeak Based Sensing and Monitoring System for IoT with Matlab Analysis," *International Journal of New Technology and Research (IJNTR)*, vol. 2, no. 6, pp. 19-23, June 2016.
- [6] I. Ejodamen, "Arduino-Based Weather Monitoring System," in *SMART- SMART-iSTEAMS Multidisciplinary Conference*, Ogwuashi-uku, Delta State, Nigeria, 2018.
- [7] E. V. Pius, "Arduino-Based Weather Monitoring System," in *SMART- SMART-iSTEAMS Multidisciplinary Conference*, Nigeria, February 2018.
- [8] D. T. Alemayehu, "Water Productivity & Sugar Cane Production," Directorate-General for International Cooperation (DGIS) of the Ministry of Foreign Affairs of the Netherlands under the DGIS UNESCO-IHE Programmatic Cooperation (DUPC)..
- [9] Y. Ibrahim, "Farm Automation System in Agriculture," Uttar Pradesh, 2019.
- [10] N. T. Antonis, "Internet of Things in agriculture, recent advances and future challenges,Constantinos Kittas," *Biosystem Engineering*, vol. 1, pp. 31-48, 2017.
- [11] P. F. Ovidiu Vermesan, "Internet of Things From Research and Innovation to Market Deployment", River Publishers Series in Communication, 2014.
- [12] A. K. Pavankumar Naik, "Automation of Irrigation System Using IoT," *International Journal of Engineering and Manufacturing Science*, vol. 8, pp. 77-88, 2018.
- [13] J. M. Bhumika, "IoT BASED SMART AGRICULTURE MONITORING SYSTEM," Jaypee University of Information Technology, Wagnaghat, July 2018 to May 2019.
- [14] P. M. Manohar, "A Survey on Internet of Things Case Studies, Applications and Future Directions," *Springer International Publishing AG 2017*, vol. 2, pp. 282-283, 2017.

- [15] S. R. Balaji Subramanian, "IoT Technology, Applications and Challenges: A Contemporary Survey," p. 8, 20 September 2019.
- [16] J. D. Sheik, "Review on Applications of Internet of Things (IoT)," pp. 841-845, 12 December 2018.
- [17] M. K. Reddy, "Applications of IoT," Special Issue Published in International Journal of Trend in Research and Development (IJTRD),, India, 2018.
- [18] A. D. Kumar, "The Internet of Things: An Opportunity for Transportation and Logistics," in *IEEE Xplore Compliant*, Odisha, India, 2017.
- [19] N. P. Sastra, "Environmental monitoring as an IoT application in building smart campus of Universitas Udayana," in *Universitas Udayana*, Denpasar, Indonesia, 2016.
- [20] W. S. X. W. Chen Yang, "Applications of Internet of Things in Manufacturing," Ontario, 2016.
- [21] R. Gamage, "A Review on Applications of Internet Of Things (IOT) in Healthcare," *Journal of the American Society for Information Science and Technolo*, pp. 1-7, June 2020.
- [22] P. Kousalya, "IOT Based Smart Security and Smart Home Automation," *International Journal of Engineering Research & Technology*, vol. 7, no. 04, pp. 43-46, 2018.
- [23] s. d. M, "Review on Applications of Internet of Things (IoT)," *International Journal of Advanced Research in Computer Engineering & Technology*, vol. 7, no. 12, pp. 841-845, 2018.
- [24] H. Madushanki, "Adoption of the Internet of Things (IoT) in Agriculture and Smart Farming towards Urban Greening," *International Journal of Advanced Computer Science and Applications*, vol. 10, no. 4, pp. 11-28, 2019.
- [25] M. Azeem, "A Review of Agro-Industry in IoT Applications and Challenges," *QUEST RESEARCH JOURNAL*, vol. 17, pp. 28-33, June 2019.
- [26] T. Shilpa, "Agricultural Crop Monitoring Sensors using IoT," in *International Journal of Engineering Research & Technology (IJERT)*, Karnataka, 2018.
- [27] T. Soni, "GREENHOUSE CONTROLLING SYSTEM USING GSM," *International Journal of Engineering Research and General Science*, vol. 4, no. 5, pp. 126-129, 2016.
- [28] T. Shah, "Livestock Monitoring in Agriculture using IoT," *International Research Journal of Engineering and Technology*, vol. 6, no. 4, pp. 2414-2418, 2019.



- [29] E. B.V., "IoT-based Irrigation Management for Smallholder Farmers in Rural Sub-Saharan Africa," in *The 11th International Conference on Emerging Ubiquitous Systems and Pervasive Networks*, Madeira, 2020.
- [30] J. Bedrae, "Development of Smart Irrigation System," *International Research Journal of Engineering and Technology*, vol. 5, no. 6, pp. 2855-2859, 2018.
- [31] A. Rewatkar, "IOT BASED SMART REAL TIME AGRICULTURE WAREHOUSE MONITORING AND CONTROL SYSTEM," *INTERNATIONAL JOURNAL OF RESEARCH IN ELECTRONICS AND COMPUTER ENGINEERING*, vol. 7, no. 1, pp. 856-859, 2019.
- [32] I. Abdullah, "An IoT Based System for Remote Monitoring of Soil Characteristics," Aligarh, 2018.
- [33] C. Adrian, "Designing the Internet of Things", UK: 2014 John Wiley and Sons Ltd, 2014.
- [34] L. Li, "Design and Implementation of Sugarcane Growth Monitoring System based on RFID and ZigBee," *IJOE*, China, 2018.
- [35] R. T. Mohammed, "Architecting the Internet of Things: State of the Art," in *Robots and Sensor Clouds*, Springer Book Series, August 2015, pp. 1-23.
- [36] E. I. Agency, "Investment Opportunity Profile for Sugar cane Plantation and Processing in Ethiopia," Ethiopian Investment Agency, Addis Abeba, 2012.
- [37] S. Corporation, "Standard Operating Procedures for Sugarcane Production at Wonji-Shoa Sugar Factory," Sugar Corporation Research and Development Center, Wonji, October 2016.
- [38] A. Ruffeis, "Environmental Impact Analysis of Two Large Scale Irrigation Schemes in Ethiopia," pp. 370-380.
- [39] G. A. Adnan, "Factors Affecting Sugarcane Production in Pakistan," *Pakistan Journal of Commerce and Social Sciences*, vol. 7, pp. 128-140, 2013.
- [40] B. Ekubay, "Analysis of Technical Efficiency of Sugar Cane Production in Ethiopia," in *SMU Conference Proceedings*, Addis Ababa, 2015.
- [41] M. U. Rajakumar, "Iot Based Smart Agricultural Monitoring System," *Asian Journal of Applied Science and Technology (AJAST)*, vol. 2, pp. 474-480, April-June 2018.
- [42] E. S. Corporation, "Ethiopian Sugar Corporation," Wonji Shoa Sugar Factory, 05 08 2020. [Online]. Available: <https://etsugar.com>. [Accessed 05 08 2020].
- [43] H. Taherdoost, "Sampling Methods in Research Methodology," *International Journal of Academic Research in Management (IJARM)*, vol. 5, pp. 18-27, January 2016.

- [44] E. H. Christian, "Analyzing Talk and Text II," *Researchgets*, pp. 2-19, 25 April 2019.
- [45] Ascough, "GPS TECHNOLOGY APPLICATIONS IN SUGARCANE PRODUCTION," *Booker Tate Ltd*, pp. 1-10, 17 October 2013.
- [46] K. S. Gunarathna, "Optimized Subsurface Irrigation System: The Future of Sugarcane Irrigation," *ResearchGats*, pp. 1-14, 13 March 2018.
- [47] P. S. Arun, "DRIP IRRIGATION IN SUGARCANE," *Agricultural Economics Research Review*, vol. 23, pp. 210-219, 2012.
- [48] N. K. Nandha Kumar, "Aurdino based Automatic Plant Watering System with Internet of Things," *International Journal of Advanced Research in Electrical, Electronics and Instrumentation Engineering*, vol. Vol. 6, no. Issue 3, pp. 2012-2019, March 2017.
- [49] U. V. Pius, "Arduino-Based Weather Monitoring System," in *SMART- SMART-iSTEAMS Multidisciplinary Conference*, Ogbuashi-uku, February 2018.
- [50] arduino, "arduino.cc," arduino, 10 December 2020. [Online]. Available: <https://www.arduino.cc>. [Accessed 2021].
- [51] M. A. Mythili, "IoT Based Smart Farm Monitoring System," *International Journal of Recent Technology and Engineering (IJRTE)*, Vols. Volume-8, no. 4, pp. 5490-5494, November 2019.
- [52] J. Safal, "Atmospheric Data Measurement using Can-Sat and Data Logging in Ground Station," ORION Space Pvt. Ltd., Bhaktapur, 2017.
- [53] Lastminute, "lastminuteengineers," lastminuteengineers, 25 Dec 2020. [Online]. Available: <https://lastminuteengineers.com>. [Accessed 25 Dec 2020].
- [54] F. Project, "duino4projects," For Project, [Online]. Available: <https://duino4projects.com>. [Accessed 26 October 2020].
- [55] GeneratePress, "Components Monofindia," components, 22 February 2021. [Online]. Available: <https://components.monofindia.com>. [Accessed 27 February 2021].

## APPENDIX

### Appendix A- Interview question

My name is Biruk Abate. I am a student of St. Mary's University, School of Graduate Studies, and Computer Science Department. This Interview is prepared to gather information for the study to be conducted on improving sugarcane production using IoT: The Case of Wonji/Shoa sugar factory. The purpose of this self-administered interview question is to collect data from Agronomist, field coordinator, sugarcane researchers and irrigation experts in order to identify the existing practice of production of sugarcane and challenges with the aim of designing IoT based sugarcane production artifact. I thank you in advance for taking your time to answer the questions.

- What are the challenges faced in Sugarcane Production?

---

---

---

---

- What are the optimum good conditions for the sugarcane crops grown in the field?

---

---

---

---

- Have you used sugarcane production management systems before? If yes, what are your key challenges when engaging with IoT applications?

---

---

---

- Does your organization have a IoT based sugarcane production management system?

---

---

---

- How many days to give a water for each sugarcane field?

---

---

---

- How to monitor environmental conditions of sugarcane pant?

---

---

---

## Appendix B- Evaluation Question

Instruction: Please put (√) on the level you agree for each evaluation question. The level scale is from 1 to 5. (Strongly agree=5, agree=4, neutral =3, disagree=2, strongly disagree=1).

Evaluation Questions		Values				
		1	2	3	4	5
1	The System is easy to learn?					
2	The System is easy to use?					
3	The IoT platform well organized and functions are easy to find?					
4	The user Interface of the system is pleasant?					
5	Are you confident to use the system?					
6	The system response is quick?					
7	The system is helpful to use?					
8	Do you think people would learn to use this system very quickly?					
9	Do you think that you wouldn't need the support of a technical person to be able to use this system?					
10	Do you find the various functions in this system were well integrated?					
11	How successful is our software in performing its intended task?					
12	What is your overall satisfaction of the system?					

## Appendix C- Humidity and Temperature Sensor

```
#include "DHT.h"
#define DHTPIN 2 // what pin we're connected to
#define DHTTYPE DHT11 // DHT 11
// Initialize DHT sensor for normal 16mhz Arduino
DHT dht(DHTPIN, DHTTYPE);
void setup() {
  Serial.begin(9600);
  Serial.println("DHTxx test!");
  dht.begin();
}
void loop() {
  // Wait a few seconds between measurements.
  delay(2000);
  // Reading temperature or humidity takes about 250 milliseconds!
  // Sensor readings may also be up to 2 seconds 'old' (it's a very slow sensor)
  float h = dht.readHumidity();
  // Read temperature as Celsius
  float t = dht.readTemperature();
  // Read temperature as Fahrenheit
  float f = dht.readTemperature(true);
  // Check if any reads failed and exit early (to try again).
  if (isnan(h) || isnan(t) || isnan(f)) {
    Serial.println("Failed to read from DHT sensor!");
    return;
  }
  // Compute heat index
  // Must send in temp in Fahrenheit!
  float hi = dht.computeHeatIndex(f, h);
  Serial.print("Humidity: ");
  Serial.print(h);
  Serial.print(" %\t");
  Serial.print("Temperature: ");
  Serial.print(t);
  Serial.print(" %C ");
  Serial.print(f);
  Serial.println(" %F");
}
```

## Appendix D-Code for Soil moisture sensor

```
/* Change these values based on your calibration values */
#define soilWet 500 // Define max value we consider soil 'wet'
#define soilDry 750 // Define min value we consider soil 'dry'
// Sensor pins
#define sensorPower 7
#define sensorPin A0
void setup() {
  pinMode(sensorPower, OUTPUT);
  // Initially keep the sensor OFF
  digitalWrite(sensorPower, LOW);
  Serial.begin(9600);
}
void loop() {
  //get the reading from the function below and print it
  int moisture = readSensor();
  Serial.print("Analog Output: ");
  Serial.println(moisture);
  // Determine status of our soil
  if (moisture < soilWet) {
    Serial.println("Status: Soil is too wet");
  } else if (moisture >= soilWet && moisture < soilDry) {
    Serial.println("Status: Soil moisture is perfect");
  } else {
    Serial.println("Status: Soil is too dry - time to water!");
  }
  delay(1000); // Take a reading every second for testing
  // Normally you should take reading perhaps once or twice a day
  Serial.println();
}
// This function returns the analog soil moisture measurement
int readSensor() {
  digitalWrite(sensorPower, HIGH); // Turn the sensor ON
  delay(10); // Allow power to settle
  int val = analogRead(sensorPin); // Read the analog value form sensor
  digitalWrite(sensorPower, LOW); // Turn the sensor OFF
  return val; // Return analog moisture value
}
```

## Appendix E-Code for GSM/GPRS Module

```
#include <SoftwareSerial.h>
SoftwareSerial gprsSerial(2,3);
#include <String.h>
#include <DHT.h>
#define DHTPIN A0
DHT dht(DHTPIN, DHT11);
void setup()
{
  gprsSerial.begin(9600); // the GPRS baud rate
  Serial.begin(9600); // the GPRS baud rate
  dht.begin();
  delay(1000);
}
void loop()
{
  float h = dht.readHumidity();
  float t = dht.readTemperature();
  delay(100);
  Serial.print("Temperature = ");
  Serial.print(t);
  Serial.println(" °C");
  Serial.print("Humidity = ");
  Serial.print(h);
  Serial.println(" %");
  if (gprsSerial.available())
  Serial.write(gprsSerial.read());
  gprsSerial.println("AT");
  delay(1000);
  gprsSerial.println("AT+CPIN?");
  delay(1000);
  gprsSerial.println("AT+CREG?");
  delay(1000);
  gprsSerial.println("AT+CGATT?");
  delay(1000);
  gprsSerial.println("AT+CIPSHUT");
  delay(1000);
  gprsSerial.println("AT+CIPSTATUS");
  delay(2000);
  gprsSerial.println("AT+CIPMUX=0");
  delay(2000);
  ShowSerialData();
  gprsSerial.println("AT+CSTT=\"etc.com\""); //start task and setting the APN,
  delay(1000);
  ShowSerialData();
  gprsSerial.println("AT+CIICR"); //bring up wireless connection
```



```

delay(3000);
ShowSerialData();
gprsSerial.println("AT+CIFSR");//get local IP address
delay(2000);
ShowSerialData();
gprsSerial.println("AT+CIPSPRT=0");
delay(3000);
ShowSerialData();gprsSerial.println("AT+CIPSTART=\"TCP\", \"api.ThingSpeak.com\", \"80
\");//start up the connection
delay(6000);
ShowSerialData();
gprsSerial.println("AT+CIPSEND");//begin send data to remote server
delay(4000);
ShowSerialData();
String str="GET https://api.ThingSpeak.com/update?api_key= L6AUCKJTV2AABJ67
&field1=" + String(t) +"&field2="+String(h);Serial.println(str);

gprsSerial.println(str);//begin send data to remote server
delay(4000);
ShowSerialData();
gprsSerial.println((char)26);//sending
delay(5000);//waitting for reply, important! the time is base on the condition of internet
gprsSerial.println();
ShowSerialData();
gprsSerial.println("AT+CIPSHUT");//close the connection
delay(100);
ShowSerialData();
}
void ShowSerialData()
{
while(gprsSerial.available()!=0)
Serial.write(gprsSerial.read());
delay(5000);
}

```